

Masoneilan® 21000 Series Control Valves

Specification Data

CH1080

01/02



**Complete Line of
Rugged, Top Guided,
Globe Valves with
Lo-dB®/Anti-Cavitation
Capabilities**

DRESSER

Table of Contents

Features	2
Numbering System	3
General Data.....	3
Temperature Range/Seat Leakage.....	4
Ratings/Connections.....	4
C _v and F _L versus Travel.....	5
Materials of Construction	
Standard - Carbon Steel, Stainless Steel.....	11
Optional Configurations and Materials	12
Bellows Seal.....	15
NACE Construction	17
Dimensions	18
Weights	21
Accessories and Options	22
Sales Offices and Distribution Centers	Back Cover

Features

21000 Series single ported, heavy top guided control valves are designed with built in versatility making them well-suited to handle a wide variety of process applications. Standard features include:

Top Guided

Rugged, heavy top plug guiding provides maximum support to ensure plug stability.

Single and Double Stage

Lo-dB®/Anti-cavitation Trim

Replacing the conventional plug with the Lo-dB®/Anti-cavitation design provides excellent noise attenuation or cavitation control.

Reduced Capacity

A series of reduced area trim is available to provide wide flow range capabilities in all valve sizes.

High Pressure Capability

A variety of actuators are available to handle low to high pressure drop requirements. Allowable pressure drops for specific leakage classes are available in Masoneilan document PH1080, or can be calculated using the Masoneilan Sizing and Selection Program.

Tight Shutoff

Class IV leakage is standard. Optional constructions meet IEC 534-4 and ANSI/FCI 70.2 Class V and VI.

Hardened Trim

Provided as standard to handle high pressure drop applications.

Trim Type

Standard construction offers either a quick change or threaded seat ring.

Environmental Packing

Low emission LE® Packing is available to assure compliance with latest environmental regulations.

Emissions Free

Bellows seal design option is available to meet zero emissions requirements.

NACE Compliance

The 21000 Series is available for Sour Service Applications using design and construction methods in accordance with NACE Standard MR 0175.

Trade names noted throughout are for reference only. Masoneilan reserves the right to supply trade named material or its equivalent.

Numbering System

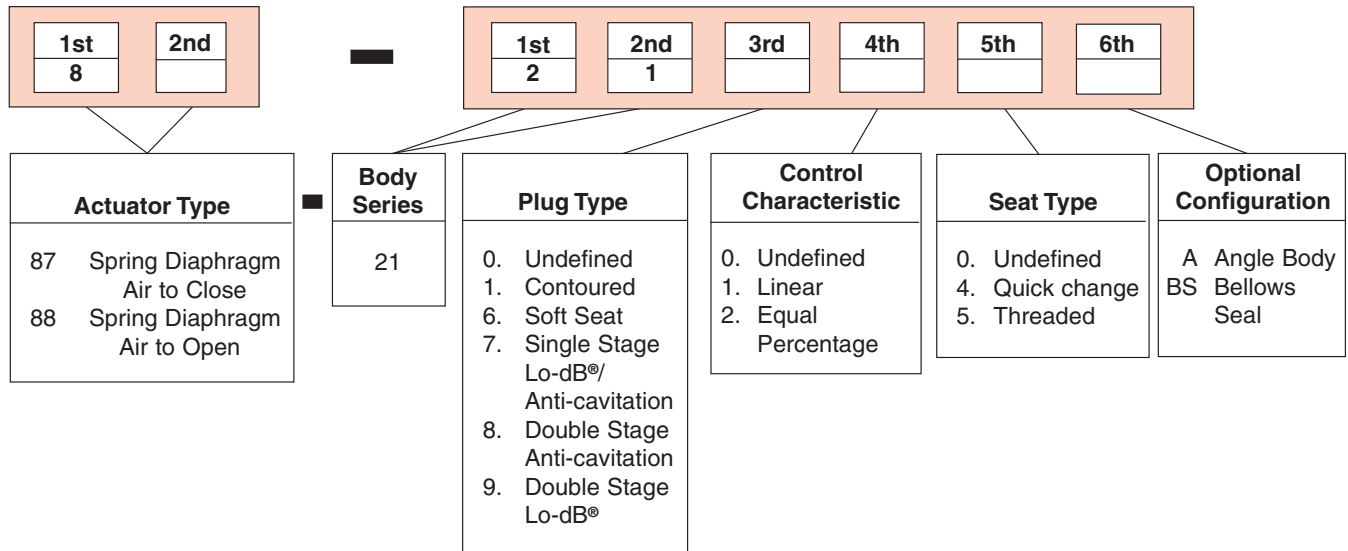

General Data

- Flow Direction**

contoured: flow-to-open
 Lo-dB®: flow-to-open
 anti-cavitation: flow-to-close

- Body**

type: high capacity globe
 high capacity angle

- Bonnet**

type: bolted
 standard
 extension

- Body and Bonnet**

materials: carbon steel
 316 stainless steel
 chrome-molybdenum steel
 others

- Trim**

plug type: contoured
 soft seat
 Lo-dB® (1 or 2 stages)
 anti-cavitation (1 or 2 stages)
 seat ring: threaded
 quick change
 guide: heavy top guided
 capacity: full area
 reduced capacity in all sizes
 C_v ratio: 50:1
 flow characteristic: linear
 equal percentage

- Actuator**

type: spring diaphragm
 handwheel: optional

Temperature Range/Seat Leakage

Contoured Trim

Valve Size		Body ⁽¹⁾ Rating	Seat Type	Packing Material	Temperature Range ⁽²⁾				Seat Leakage, IEC 534-4 and ANSI/FCI 70.2 Class	
					Standard Bonnet		Extension Bonnet			
inch	mm				min.	max.	min.	max.		
.75 to 6	20 to 150	ANSI Class 150 to 2500 and equivalent PN	Metal	PTFE or LE [®] Packing	-20°F (-29°C)	+450°F (+232°C)	-20°F (-29°C)	+800°F (+427°C)	IV	V
				Flexible Graphite	-20°F (-29°C)	+800°F (+427°C)	-20°F (-29°C)	+800°F (+427°C)		
			Soft Seat	Any	-20°F (-29°C)	+450°F (+232°C)	-20°F (-29°C)	+450°F (+232°C)	VI	

Lo-dB[®]/Anti-Cavitation Trim (1 or 2 Stage Design)⁽³⁾

Valve ⁽⁴⁾ Size		Body ⁽¹⁾ Rating	Seat Type	Packing Material	Temperature Range ⁽²⁾				Seat Leakage, IEC 534-4 and ANSI/FCI 70.2 Class	
					Standard Bonnet		Extension Bonnet			
inch	mm				min.	max.	min.	max.		
.75 to 6	20 to 150	ANSI Class 150 to 2500 and equivalent PN	Metal	PTFE or LE [®] Packing	-20°F (-29°C)	+450°F (+232°C)	-20°F (-29°C)	+800°F (+427°C)	IV	V
				Flexible Graphite	-20°F (-29°C)	+800°F (+427°C)	-20°F (-29°C)	+800°F (+427°C)		

1. ANSI Class 900 to 2500 available only in .75 to 2 inch (20 to 50 mm) sizes.
2. See Materials of Construction Tables for other temperature limitations.
3. 2-Stage design only available with Quick Change seat rings.
4. 2-Stage Anti-Cavitation Trim not available in 6 inch (150 mm) size.

Ratings/Connections^①

RF Flanged
 Socket Weld
 Threaded
 RT Joint
 Butt Weld

Valve ⁽²⁾ Size		ANSI Class 150 to 600 and equivalent PN				ANSI Class 900 to 2500 ⁽³⁾ and equivalent PN			
inch	mm	<input type="checkbox"/>	<input checked="" type="checkbox"/>	<input type="checkbox"/>	<input type="checkbox"/>	<input type="checkbox"/>	<input checked="" type="checkbox"/>	<input type="checkbox"/>	<input checked="" type="checkbox"/>
.75 to 2	20 to 50	<input type="checkbox"/>	<input checked="" type="checkbox"/>	<input type="checkbox"/>	<input type="checkbox"/>	<input type="checkbox"/>	<input checked="" type="checkbox"/>	<input type="checkbox"/>	<input checked="" type="checkbox"/>
3 to 6	80 to 150	<input type="checkbox"/>		<input type="checkbox"/>	<input type="checkbox"/>	<input type="checkbox"/>	<input checked="" type="checkbox"/>	See 41005 Series	

1. Standard flange finish of Ra 125-250. Other flange facings and surface finishes available.
2. Sizes, ratings and end connections available in both globe and angle body styles.
3. Butt weld end connections for ANSI Class 900 to 2500 available only in 2 inch (50 mm) size.

C_v and F_L versus Travel for 21100 and 21600 Series

Contoured Trim

Body Rating: ANSI Class 150 to 600

Sizes: DN 20 to DN 150 - .75" through 6"

Flow Characteristic: **LINEAR**

Percent of Travel						10	20	30	40	50	60	70	80	90	100
F _L						0.93	0.93	0.92	0.92	0.91	0.91	0.91	0.90	0.90	0.90
Valve Size		Orifice Diameter		Travel		Rated C _v									
.75 & 1	20 & 25	0.250	6.4	0.8	20.3	0.01	0.02	0.03	0.04	0.05	0.06	0.07	0.08	0.10	0.11
						0.03	0.06	0.08	0.11	0.13	0.16	0.19	0.23	0.27	0.3
						0.06	0.12	0.17	0.22	0.27	0.32	0.38	0.45	0.54	0.6
						0.15	0.31	0.46	0.60	0.77	0.94	1.1	1.3	1.5	1.7
		0.375	9.5	0.8	20.3	0.34	0.68	1.0	1.3	1.7	2.1	2.5	2.9	3.3	3.8
		0.500	12.7	0.8	20.3	0.54	1.1	1.6	2.1	2.7	3.3	4.0	4.6	5.3	6
		0.812	20.6	0.8	20.3	1.1	2.2	3.2	4.3	5.4	6.7	7.9	9.2	11	12
1.5	40	0.250	6.4	0.8	20.3	0.01	0.02	0.03	0.04	0.05	0.06	0.07	0.08	0.10	0.11
						0.03	0.06	0.08	0.11	0.13	0.16	0.19	0.23	0.27	0.3
						0.06	0.12	0.17	0.22	0.27	0.32	0.38	0.45	0.54	0.6
						0.15	0.31	0.46	0.60	0.77	0.94	1.1	1.3	1.5	1.7
		0.375	9.5	0.8	20.3	0.34	0.68	1.0	1.3	1.7	2.1	2.5	2.9	3.3	3.8
		0.500	12.7	0.8	20.3	0.54	1.1	1.6	2.1	2.7	3.3	4.0	4.6	5.3	6
		0.812	20.6	0.8	20.3	1.2	2.3	3.5	4.6	5.9	7.2	8.6	10	11	13
1.250	31.8	0.8	20.3	2.3	4.5	6.8	8.9	11	14	17	19	22	25		
		1.625	41.3	0.8	20.3	3.2	6.3	9.5	12	16	19	23	27	31	35
2	50	0.250	6.4	0.8	20.3	0.01	0.02	0.03	0.04	0.05	0.06	0.07	0.08	0.10	0.11
						0.03	0.06	0.08	0.11	0.13	0.16	0.19	0.23	0.27	0.3
						0.06	0.12	0.17	0.22	0.27	0.32	0.38	0.45	0.54	0.6
						0.15	0.31	0.46	0.60	0.77	0.94	1.1	1.3	1.5	1.7
		0.375	9.5	0.8	20.3	0.34	0.68	1.0	1.3	1.7	2.1	2.5	2.9	3.3	3.8
		0.500	12.7	0.8	20.3	0.54	1.1	1.6	2.1	2.7	3.3	4.0	4.6	5.3	6
		0.812	20.6	0.8	20.3	1.4	2.7	4.1	5.3	6.8	8.3	9.9	12	13	15
1.250	31.8	0.8	20.3	2.3	4.7	7.0	9.2	12	14	17	20	23	26		
		1.625	41.3	0.8	20.3	4.1	8.3	12	16	21	26	30	35	40	46
3	80	1.250	31.8	1.5	38.1	2.8	5.6	8.4	11	14	17	20	24	27	31
		1.625	41.3	1.5	38.1	4.2	8.5	13	17	21	26	31	36	41	47
		2.625	66.7	1.5	38.1	9.9	20	30	39	50	61	73	85	97	110
4	100	1.625	41.3	1.5	38.1	4.4	8.8	13	17	22	27	32	38	43	49
		2.625	66.7	1.5	38.1	10	20	31	40	51	63	75	87	99	113
		3.500	88.9	1.5	38.1	18	35	53	69	88	108	129	150	172	195
6	150	2.625	66.7	2.0	50.8	11	23	34	45	57	70	83	97	111	126
		3.500	88.9	2.0	50.8	19	37	56	74	94	115	137	160	183	208
		5.000	127.0	2.0	50.8	36	72	108	142	180	222	264	308	352	400

Note: Standard Bellows Seal construction available for ANSI Class 150 - 300 and capacities of C_v = 1.7 and higher.

 Quick Change Trim Only

C_v and F_L versus Travel for 21100 and 21600 Series

Contoured Trim

Body Rating: ANSI Class 150 to 600

Sizes: DN 20 to DN 150 - .75" to 6"

Flow Characteristic: **EQUAL PERCENTAGE**

Percent of Travel						10	20	30	40	50	60	70	80	90	100
F _L						0.93	0.93	0.93	0.93	0.93	0.92	0.92	0.91	0.91	0.9
Valve Size		Orifice Diameter		Travel		Rated C _v									
inches	mm	inches	mm	inches	mm										
.75 & 1.00	20 & 25	0.375	9.5	0.8	20.3	0.11	0.17	0.25	0.40	0.66	1.1	1.8	2.5	3.3	3.8
		0.500	12.7	0.8	20.3	0.18	0.27	0.40	0.63	1.0	1.8	2.8	4.0	5.2	6
		0.812	20.6	0.8	20.3	0.43	0.61	0.84	1.3	2.3	4.3	6.8	8.9	11	12
1.50	40	0.375	9.5	0.8	20.3	0.11	0.17	0.25	0.40	0.66	1.1	1.8	2.5	3.3	3.8
		0.500	12.7	0.8	20.3	0.18	0.27	0.40	0.63	1.05	1.8	2.8	4.0	5.2	6
		0.812	20.6	0.8	20.3	0.39	0.58	0.86	1.36	2.3	3.9	6.1	8.6	11	13
		1.250	31.8	0.8	20.3	0.90	1.28	1.76	2.8	4.7	9.0	14	19	22	25
2	50	0.375	9.5	0.8	20.3	0.11	0.17	0.25	0.40	0.66	1.1	1.8	2.5	3.3	3.8
		0.500	12.7	0.8	20.3	0.18	0.27	0.40	0.63	1.0	1.8	2.8	4.0	5.2	6
		0.812	20.6	0.8	20.3	0.45	0.67	0.99	1.6	2.6	4.5	7.0	9.9	13	15
		1.250	31.8	0.8	20.3	0.77	1.2	1.7	2.7	4.5	7.7	12	17	23	26
		1.625	41.3	0.8	20.3	1.7	2.3	3.2	5.1	8.7	17	26	34	41	46
3	80	1.250	31.8	1.5	38.1	0.92	1.4	2.0	3.2	5.4	9.2	15	20	27	31
		1.625	41.3	1.5	38.1	1.4	2.1	3.1	4.9	8.2	14	22	31	41	47
		2.625	66.7	1.5	38.1	4.0	5.6	7.7	12	21	40	62	82	98	110
4	100	1.625	41.3	1.5	38.1	1.5	2.2	3.2	5.1	8.5	15	23	32	43	49
		2.625	66.7	1.5	38.1	3.4	5.0	7.5	12	20	34	53	75	99	113
		3.500	88.9	1.5	38.1	7.1	10.0	13.7	22	37	70	110	145	174	195
6	150	2.625	66.7	2.0	50.8	3.8	5.6	8.3	13	22	38	59	83	110	126
		3.500	88.9	2.0	50.8	6.2	9.3	14	22	36	62	97	137	181	208
		5.000	127.0	2.0	50.8	14	20	28	44	76	144	226	298	357	400

21700 Series

Single Stage Lo-dB®/Anti-Cavitation Trim

Body Rating: ANSI Class 150 to 600

Sizes: DN 20 to DN 150 - .75" to 6"

Flow Characteristic: **LINEAR**

Percent of Travel						10	20	30	40	50	60	70	80	90	100
F _L						0.93	0.93	0.93	0.93	0.93	0.93	0.93	0.93	0.93	0.93
Valve Size		Orifice Diameter		Travel		Rated C _v									
inches	mm	inches	mm	inches	mm										
.75 & 1	20 & 25	0.812	20.6	0.8	20.3	0.40	0.80	1.2	1.6	2.0	2.4	2.8	3.2	3.6	4
						0.80	1.6	2.4	3.2	4.0	4.8	5.6	6.4	7.2	8
1.5	40	1.250	31.8	0.8	20.3	0.80	1.6	2.4	3.2	4.0	4.8	5.6	6.4	7.2	8
						1.5	3.0	4.5	6.0	7.5	9.0	10.5	12.0	13.5	15
2	50	1.250	31.8	0.8	20.3	0.80	1.6	2.4	3.2	4.0	4.8	5.6	6.4	7.2	8
						1.5	3.0	4.5	6.0	7.5	9.0	10.5	12.0	13.5	15
		1.625	41.3	0.8	20.3	2.5	5.0	7.5	10.0	12.5	15.0	17.5	20.0	22.5	25
3	80	2.625	66.7	1.5	38.1	4.8	9.6	14.4	19.2	24.0	28.8	33.6	38.4	43.2	48
						7.5	15.0	22.5	30.0	37.5	45.0	52.5	60.0	67.5	75
4	100	2.625	66.7	1.5	38.1	6.3	12.6	18.9	25.2	31.5	37.8	44.1	50.4	56.7	63
		3.500	88.9	1.5	38.1	10	20	30	40	50	60	70	80	90	100
6	150	5.000	127.0	2.0	50.8	15	30	45	60	75	90	105	120	135	150
						20	40	60	80	100	120	140	160	180	200

Quick Change Trim Only

C_v and F_L versus Travel for 21800 Series

Double Stage Anti-Cavitation Trim

Body Rating: ANSI Class 150 to 600

Sizes: DN 20 to DN 100 - .75" to 4"

Flow Characteristic: **LINEAR**

Percent of Travel						10	20	30	40	50	60	70	80	90	100	
F _L						0.975	0.975	0.975	0.975	0.975	0.975	0.975	0.975	0.975	0.975	0.975
Valve Size		Orifice Diameter		Travel		Rated C _v										
inches	mm	inches	mm	inches	mm											
.75 & 1	20 & 25	0.812	20.6	0.8	20.3	0.23	0.46	0.7	0.9	1.2	1.4	1.6	1.8	2.1	2.3	
						0.45	0.9	1.4	1.8	2.3	2.7	3.2	3.6	4.1	4.5	
1.5	40	0.812	20.6	0.8	20.3	0.23	0.5	0.7	0.9	1.2	1.4	1.6	1.8	2.1	2.3	
						0.45	0.9	1.4	1.8	2.3	2.7	3.2	3.6	4.1	4.5	
		1.250	31.8	0.8	20.3	0.9	1.7	2.6	3.4	4.3	5.1	6.0	6.8	7.7	8.5	
2	50	1.250	31.8	0.8	20.3	0.45	0.9	1.4	1.8	2.3	2.7	3.2	3.6	4.1	4.5	
						0.9	1.7	2.6	3.4	4.3	5.1	6.0	6.8	7.7	8.5	
		1.625	41.3	0.8	20.3	1.4	2.8	4.2	5.6	7.0	8.4	9.8	11.2	12.6	14	
3	80	2.625	66.7	1.5	38.1	2.7	5.4	8.1	10.8	13.5	16.2	18.9	21.6	24.3	27	
						4.2	8.4	12.6	16.8	21	25.2	29.4	33.6	37.8	42	
4	100	2.625	66.7	1.5	38.1	4	8	12	16	20	24	28	32	36	40	
						3.500	88.9	1.5	38.1	6	12	19	25	31	37	43

Note: Double stage anti-cavitation trim not available with Bellows Seal construction.

21900 Series

Double Stage Lo-dB® Trim

Body Rating: ANSI Class 150 to 600

Sizes: DN 20 to DN 150 - .75" to 6"

Flow Characteristic: **LINEAR**

Percent of Travel						10	20	30	40	50	60	70	80	90	100	
F _L						0.975	0.975	0.975	0.975	0.975	0.975	0.975	0.975	0.975	0.975	0.975
Valve Size		Orifice Diameter		Travel		Rated C _v										
inches	mm	inches	mm	inches	mm											
.75 & 1	20 & 25	0.812	20.6	0.8	20.3	0.35	0.70	1.1	1.4	1.8	2.1	2.5	2.8	3.2	3.5	
						0.57	1.1	1.7	2.3	2.9	3.4	4.0	4.6	5.1	5.7	
1.5	40	1.250	31.8	0.8	20.3	0.70	1.4	2.1	2.8	3.5	4.2	4.9	5.6	6.3	7	
						1.3	2.6	3.9	5.2	6.5	7.8	9.1	10.4	11.7	13	
2	50	1.250	31.8	0.8	20.3	1.3	2.6	3.9	5.2	6.5	7.8	9.1	10.4	11.7	13	
						2.1	4.2	6.3	8.4	10.5	12.6	14.7	16.8	18.9	21	
3	80	2.625	66.7	1.5	38.1	4	8	12	16	20	24	28	32	36	40	
						6.3	12.6	18.9	25.2	31.5	37.8	44.1	50.4	56.7	63	
4	100	2.625	66.7	1.5	38.1	5.3	10.6	15.9	21.2	26.5	31.8	37.1	42.4	47.7	53	
						3.500	88.9	1.5	38.1	8	17	25	33	42	50	58
6	150	5.000	127	2.0	50.8	13	25	38	50	63	75	88	100	113	125	

C_v and F_L versus Travel for 21100 and 21600 Series

Contoured Trim

Body Rating: ANSI Class 900 to 2500
 Sizes: DN 20 to DN 50 - .75" through 2"

Flow Characteristic: **LINEAR**

Percent of Travel						10	20	30	40	50	60	70	80	90	100
F _L						0.93	0.93	0.92	0.92	0.91	0.91	0.91	0.90	0.90	0.90
Valve Size		Orifice Diameter		Travel		Rated C _v									
inches	mm	inches	mm	inches	mm										
.75 & 1	20 & 25	0.250	6.4	0.8	20.3	0.15	0.31	0.46	0.60	0.77	0.94	1.1	1.3	1.5	1.7
		0.375	9.5	0.8	20.3	0.34	0.68	1.0	1.3	1.7	2.1	2.5	2.9	3.3	3.8
		0.500	12.7	0.8	20.3	0.54	1.1	1.6	2.1	2.7	3.3	4.0	4.6	5.3	6
		0.812	20.6	0.8	20.3	1.1	2.2	3.2	4.3	5.4	6.7	7.9	9.2	11	12
1.5	40	0.250	6.4	0.8	20.3	0.15	0.31	0.46	0.60	0.77	0.94	1.1	1.3	1.5	1.7
		0.375	9.5	0.8	20.3	0.34	0.68	1.0	1.3	1.7	2.1	2.5	2.9	3.3	3.8
		0.500	12.7	0.8	20.3	0.54	1.1	1.6	2.1	2.7	3.3	4.0	4.6	5.3	6
		0.812	20.6	0.8	20.3	1.2	2.3	3.5	4.6	5.9	7.2	8.6	10	11	13
		1.250	31.8	0.8	20.3	2.3	4.5	6.8	8.9	11	14	17	19	22	25
		1.625	41.3	0.8	20.3	3.2	6.3	9.5	12	16	19	23	27	31	35
2	50	0.250	6.4	0.8	20.3	0.15	0.31	0.46	0.60	0.77	0.94	1.1	1.3	1.5	1.7
		0.375	9.5	0.8	20.3	0.34	0.68	1.0	1.3	1.7	2.1	2.5	2.9	3.3	3.8
		0.500	12.7	0.8	20.3	0.54	1.1	1.6	2.1	2.7	3.3	4.0	4.6	5.3	6
		0.812	20.6	0.8	20.3	1.4	2.7	4.1	5.3	6.8	8.3	9.9	12	13	15
		1.250	31.8	0.8	20.3	2.3	4.7	7.0	9.2	12	14	17	20	23	26
		1.625	41.3	0.8	20.3	4.1	8.3	12	16	21	26	30	35	40	46

■ Quick Change Trim Only

Contoured Trim

Body Rating: ANSI Class 900 to 2500
 Sizes: DN 20 to DN 50 - .75" to 2"

Flow Characteristic: **EQUAL PERCENTAGE**

Percent of Travel						10	20	30	40	50	60	70	80	90	100
F _L						0.93	0.93	0.93	0.93	0.93	0.92	0.92	0.91	0.91	0.9
Valve Size		Orifice Diameter		Travel		Rated C _v									
inches	mm	inches	mm	inches	mm										
.75 & 1.00	20 & 25	0.375	9.5	0.8	20.32	0.11	0.17	0.25	0.40	0.66	1.1	1.8	2.5	3.3	3.8
		0.500	12.7	0.8	20.3	0.18	0.27	0.40	0.63	1.0	1.8	2.8	4.0	5.2	6
		0.812	20.6	0.8	20.3	0.43	0.61	0.84	1.3	2.3	4.3	6.8	8.9	11	12
1.50	40	0.375	9.5	0.8	20.3	0.11	0.17	0.25	0.40	0.66	1.1	1.8	2.5	3.3	3.8
		0.500	12.7	0.8	20.3	0.18	0.27	0.40	0.63	1.05	1.8	2.8	4.0	5.2	6
		0.812	20.6	0.8	20.3	0.39	0.58	0.86	1.36	2.3	3.9	6.1	8.6	11	13
		1.250	31.8	0.8	20.3	0.90	1.28	1.76	2.8	4.7	9.0	14	19	22	25
2	50	0.375	9.5	0.8	20.3	0.11	0.17	0.25	0.40	0.66	1.1	1.8	2.5	3.3	3.8
		0.500	12.7	0.8	20.3	0.18	0.27	0.40	0.63	1.0	1.8	2.8	4.0	5.2	6
		0.812	20.6	0.8	20.3	0.45	0.67	0.99	1.6	2.6	4.5	7.0	9.9	13	15
		1.250	31.8	0.8	20.3	0.77	1.2	1.7	2.7	4.5	7.7	12	17	23	26
		1.625	41.3	0.8	20.3	1.7	2.3	3.2	5.1	8.7	17	26	34	41	46

ANSI Class 900 to 2500 available only in sizes .75" to 2".

C_v and F_L versus Travel for 21700 Series

Single Stage Lo-dB®/Anti-Cavitation Trim

Body Rating: ANSI Class 900 to 2500

Sizes: DN 20 to DN 50 - .75" to 2"

Flow Characteristic: **LINEAR**

Percent of Travel						10	20	30	40	50	60	70	80	90	100	
F _L						0.93	0.93	0.93	0.93	0.93	0.93	0.93	0.93	0.93	0.93	0.93
Valve Size		Orifice Diameter		Travel		Rated C _v										
inches	mm	inches	mm	inches	mm											
.75 & 1	20 & 25	0.812	20.6	0.8	20.3	0.40	0.80	1.2	1.6	2.0	2.4	2.8	3.2	3.6	4	
						0.80	1.6	2.4	3.2	4.0	4.8	5.6	6.4	7.2	8	
1.5	40	1.250	31.8	0.8	20.3	0.80	1.6	2.4	3.2	4.0	4.8	5.6	6.4	7.2	8	
						1.5	3.0	4.5	6.0	7.5	9.0	10.5	12.0	13.5	15	
2	50	1.250	31.8	0.8	20.3	0.80	1.6	2.4	3.2	4.0	4.8	5.6	6.4	7.2	8	
						1.5	3.0	4.5	6.0	7.5	9.0	10.5	12.0	13.5	15	
		1.625	41.3	0.8	20.3	2.5	5.0	7.5	10.0	12.5	15.0	17.5	20.0	22.5	25	

Quick Change Trim Only

21800 Series

Double Stage Anti-Cavitation Trim

Body Rating: ANSI Class 900 to 2500

Sizes: DN 20 to DN 50 - .75" to 2"

Flow Characteristic: **LINEAR**

Percent of Travel						10	20	30	40	50	60	70	80	90	100	
F _L						0.975	0.975	0.975	0.975	0.975	0.975	0.975	0.975	0.975	0.975	0.975
Valve Size		Orifice Diameter		Travel		Rated C _v										
inches	mm	inches	mm	inches	mm											
.75 & 1	20 & 25	0.812	20.6	0.8	20.3	0.23	0.46	0.7	0.9	1.2	1.4	1.6	1.8	2.1	2.3	
						0.45	0.9	1.4	1.8	2.3	2.7	3.2	3.6	4.1	4.5	
1.5	40	0.812	20.6	0.8	20.3	0.23	0.5	0.7	0.9	1.2	1.4	1.6	1.8	2.1	2.3	
						0.45	0.9	1.4	1.8	2.3	2.7	3.2	3.6	4.1	4.5	
		1.250	31.8	0.8	20.3	0.9	1.7	2.6	3.4	4.3	5.1	6.0	6.8	7.7	8.5	
2	50	1.250	31.8	0.8	20.3	0.45	0.9	1.4	1.8	2.3	2.7	3.2	3.6	4.1	4.5	
						0.9	1.7	2.6	3.4	4.3	5.1	6.0	6.8	7.7	8.5	
		1.625	41.3	0.8	20.3	1.4	2.8	4.2	5.6	7.0	8.4	9.8	11.2	12.6	14	

21900 Series

Double Stage Lo-dB® Trim

Body Rating: ANSI Class 900 to 2500

Sizes: DN 20 to DN 50 - .75" to 2"

Flow Characteristic: **LINEAR**

Percent of Travel						10	20	30	40	50	60	70	80	90	100	
F _L						0.975	0.975	0.975	0.975	0.975	0.975	0.975	0.975	0.975	0.975	0.975
Valve Size		Orifice Diameter		Travel		Rated C _v										
inches	mm	inches	mm	inches	mm											
.75 & 1	20 & 25	0.812	20.6	0.8	20.3	0.35	0.70	1.1	1.4	1.8	2.1	2.5	2.8	3.2	3.5	
						0.57	1.1	1.7	2.3	2.9	3.4	4.0	4.6	5.1	5.7	
1.5	40	1.250	31.8	0.8	20.3	0.70	1.4	2.1	2.8	3.5	4.2	4.9	5.6	6.3	7	
						1.3	2.6	3.9	5.2	6.5	7.8	9.1	10.4	11.7	13	
2	50	1.250	31.8	0.8	20.3	1.3	2.6	3.9	5.2	6.5	7.8	9.1	10.4	11.7	13	
						1.625	41.3	0.8	20.3	2.1	4.2	6.3	8.4	10.5	12.6	14.7

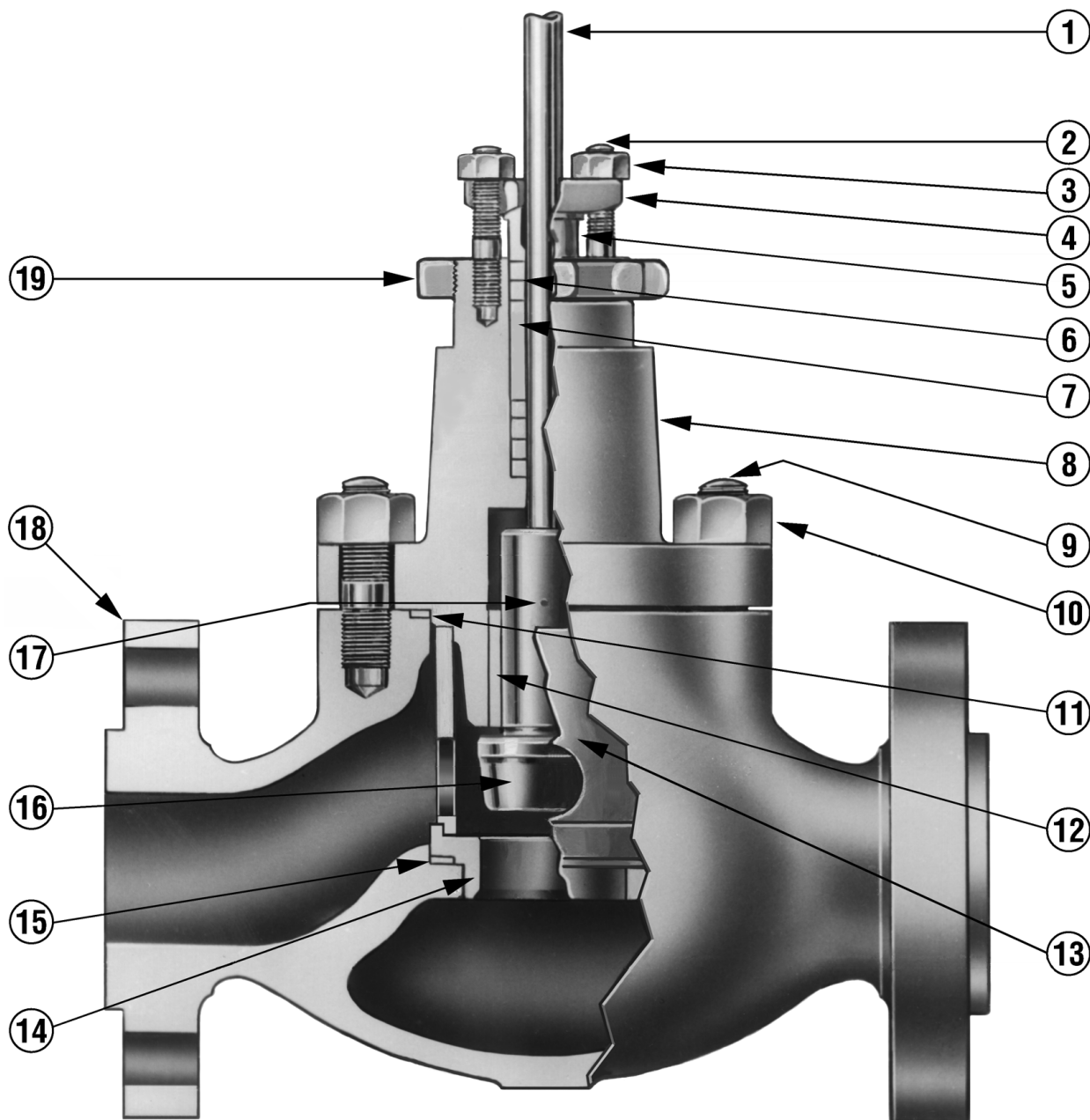

Standard Construction

Materials of Construction

Standard Carbon Steel Version

Ref. No.	Temperature Range	-20°F	450°F	650°F	800°F	
	Description	Standard Materials				
1	Plug Stem	17-4 PH St. St. ASTM A564 Gr 630				
2	Packing Flange Stud	304 St. St. ASTM A193 GR B8				
3	Packing Flange Nut	304 St. St. ASTM A194 GR 8				
4	Packing Flange	Carbon Steel ASTM A668 CL B or ASTM A216 GR WCC				
5	Packing Follower	300 Series Austenitic Stainless Steel				
6	Packing	Kevlar PTFE (Crane 285K)				
7	Lantern Ring (Optional)	300 Series Austenitic Stainless Steel				
8	Valve Bonnet	Carbon Steel ASTM A216 Grade WCC or ASTM A105				
9	Body Stud	Alloy Steel ASTM A193 GR B7				
10	Body Stud Nut	Carbon Steel ASTM A194 GR 2H				
11	Body Gasket	316L St. St. w/Flexible Graphite Filler (Spiral Wound)				
12	Guide Bushing	440C St. St. ASTM A276 TY 440C ⁽¹⁾				
13	Cage ⁽²⁾	304 St. St. ASTM A351 GR CF8				
14	Seat Ring	400 Series Martensitic Stainless Steel				
15	Seat Ring Gasket	316L St. St. w/Flexible Graphite Filler (Spiral Wound)				
16	Plug	400 Series Martensitic Stainless Steel				
17	Plug Pin	303 St. St. ASTM A582 TY 303				
18	Valve Body	Carbon Steel ASTM A216 Grade WCC				
19	Drive Nut	Carbon Steel SAE 1117 or ASTM A216 GR WCC				
Ref. No.	Temperature Range	-29°C	232°C	343°C	427°C	

- Notes:
1. 440C bushing not supplied with Stainless Steel Body/Bonnet or in combination with 316 Trim.
 2. Required for Quick Change Trim option only.

Standard Stainless Steel Version ⁽¹⁾

Ref. No.	Temperature Range	-20°F	650°F	800°F	
	Description	Standard Materials			
1	Plug Stem	316 St. St. ASTM A479 TY 316			
8	Valve Bonnet	316 St. St. ASTM A351 GR CF8M			
18	Valve Body				
12	Guide Bushing	Nitronic 60 ASTM A479 TY 21800			
14	Seat Ring	316 St. St. ASTM A479 TY 316			
16	Plug	316 St. St. ASTM A479 TY 316			
Ref. No.	Temperature Range	-29°C	343°C	427°C	

- Notes:
1. Materials for other components are same as listed for Standard Carbon Steel Version.
 2. Consult Masoneilan for material combinations for temperatures below -20°F (-29°C) or above 800°F (427°C).

Review use of optional materials and configurations for temperature ranges indicated. Standard materials listed may still be applicable depending on specific service conditions. Consult Masoneilan for appropriate material combinations.

Materials of Construction

Optional Configurations & Materials

Ref. No.	Temperature Range	-20°F	450°F	650°F	800°F
	Description	Standard Materials			
1	Plug Stem	A286 Super Alloy ASTM A638 GR 660 Inconel X-750 ASTM B637 GR 688			
6	Packing	LE® Packing ⁽¹⁾			
		Flexible Graphite			
8	Valve Bonnet	Chrome-Moly Steel ASTM A217 Grade WC9			
18	Valve Body	Chrome-Moly Steel ASTM A217 Grade WC9			
9	Body Stud ⁽²⁾	304 St. St. ASTM A193 GR B8 CL 2			
10	Body Stud Nut ⁽²⁾	304 St. St. ASTM A194 GR 8			
12	Guide Bushing	Stellite 6 UNS 30006			
13	Cage ⁽³⁾	Martensitic St. St. ASTM A487 GR CA6NM CL B			
14	Seat Ring	316 St. St. ASTM A479 TY 316 with Hardfaced Seat			
16	Plug	316 St. St. ASTM A479 TY 316 with Teflon Soft Seat			
		316 St. St. ASTM A479 TY 316 with Hardfaced Seat			
		316 St. St. ASTM A479 TY 316 with Hardfaced Seat & Guide ⁽⁴⁾			
		Stellite 6 UNS 30006 ⁽⁴⁾			
Ref. No.	Temperature Range	-29°C	232°C	343°C	427°C

- Notes:
1. LE Packing for low emissions applications is limited to maximum operating pressure of 750 psig (52 bar).
 2. Optional stainless steel bolting materials for corrosive ambient environments. Consult Maseoneilan for specific pressure and temperature limitations.
 3. Required for Quick Change Trim option only. Recommended material option for ANSI Class 900 and above.
 4. Recommended material for use along with solid Stellite bushing for applications above 650°F (343°C).
 5. Consult Maseoneilan for material combinations for temperatures below -20°F (-29°C) or above 800°F (427°C).

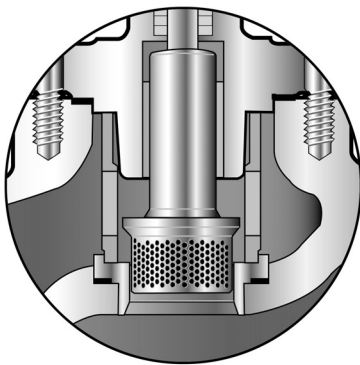

**Single Stage Lo-dB®/
Anti-Cavitation Trim**

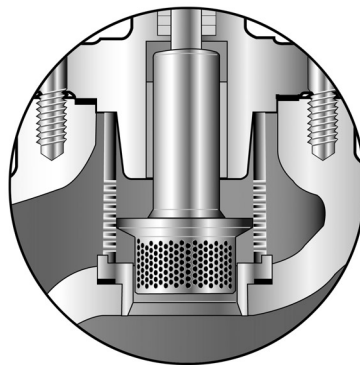

**Double Stage Lo-dB®/
Anti-Cavitation Trim**

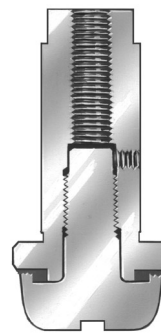

**Soft Seated
Plug S/A**

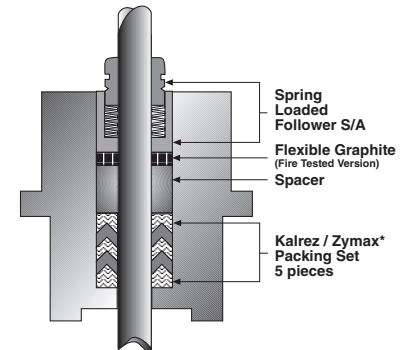

**LE® Packing System (Optional)
Low Emission Stem Packing**

* Kalrez and Zymax are registered Dupont Corporation Trademarks for Perfluoroelastomer and long carbon fiber filled PTFE, respectively.

Bellows Seal Design Features 21000 BS Series

Standard Construction

Bellows seal configuration is fully compatible with the standard 21000 Series trim and actuator options providing equivalent capacity capabilities for each valve size. The standard packing box design and packing design options are used as a secondary stem seal.

Rugged Design

The formed bellows construction is an externally pressurized design that is capable of operating up to the full valve ANSI B16.34 pressure rating. Guides are located above and below the bellows providing excellent stability to withstand flow induced and mechanical vibration.

Maximum Life

The bellows assembly is designed for 50% compression/extension (zero stress) at the valve mid-stroke position for maximum cycle life. Bellows torsional stresses are also minimized with the anti-rotation feature provided by flats on the plug stem.

High Quality

Each bellows subassembly is helium leak tested to verify weld integrity, and is also hydro-statically tested as part of the complete valve assembly. Mechanical travel stops are also designed into both the bellows and valve assemblies to prevent over compression or extension.

Smart Solution

Bellows installed cycle life can be monitored in the field by utilizing Masoneilan's SVI® Digital Positioner with actual process data. This unique preventative maintenance option will help improve plant safety by identifying potential hazardous failures before they happen, and reduce cost by eliminating premature Bellows replacement.

Bellows Materials

Standard Material

316/316L Stainless Steel

Optional Materials

Hastelloy C276

Monel 400

Inconel 625

See pages 14-15 for full materials listing.

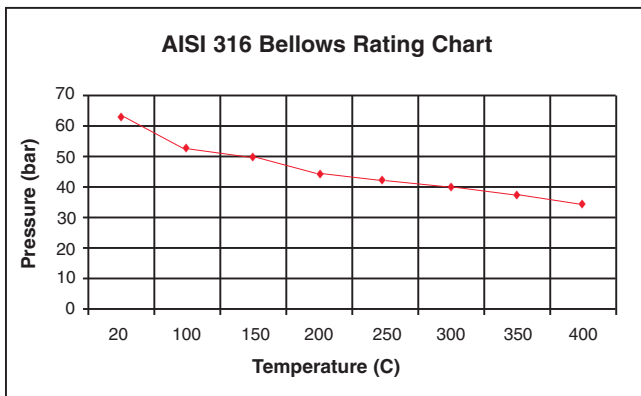

Size and Ratings

Pressure Ratings: ANSI Class 150 and 300 – PN 10 and PN 50

Valve Size	Bellows Design Stroke		Life Cycle Ratings ⁽¹⁾		
	inches	mm	Maximum Stroke		
			100%	50%	25%
.75"-2"	.75	19	100,000 Full Cycles	600,000 Full Cycles	3,000,000 Full Cycles
3"-4"	1.50	38.1			
6"	2.00	50.8			

1. Minimum expected average cycle life for Class 300 bellows operating at constant pressure.

2. Consult Masoneilan for Bellows applications above ANSI Class 300.

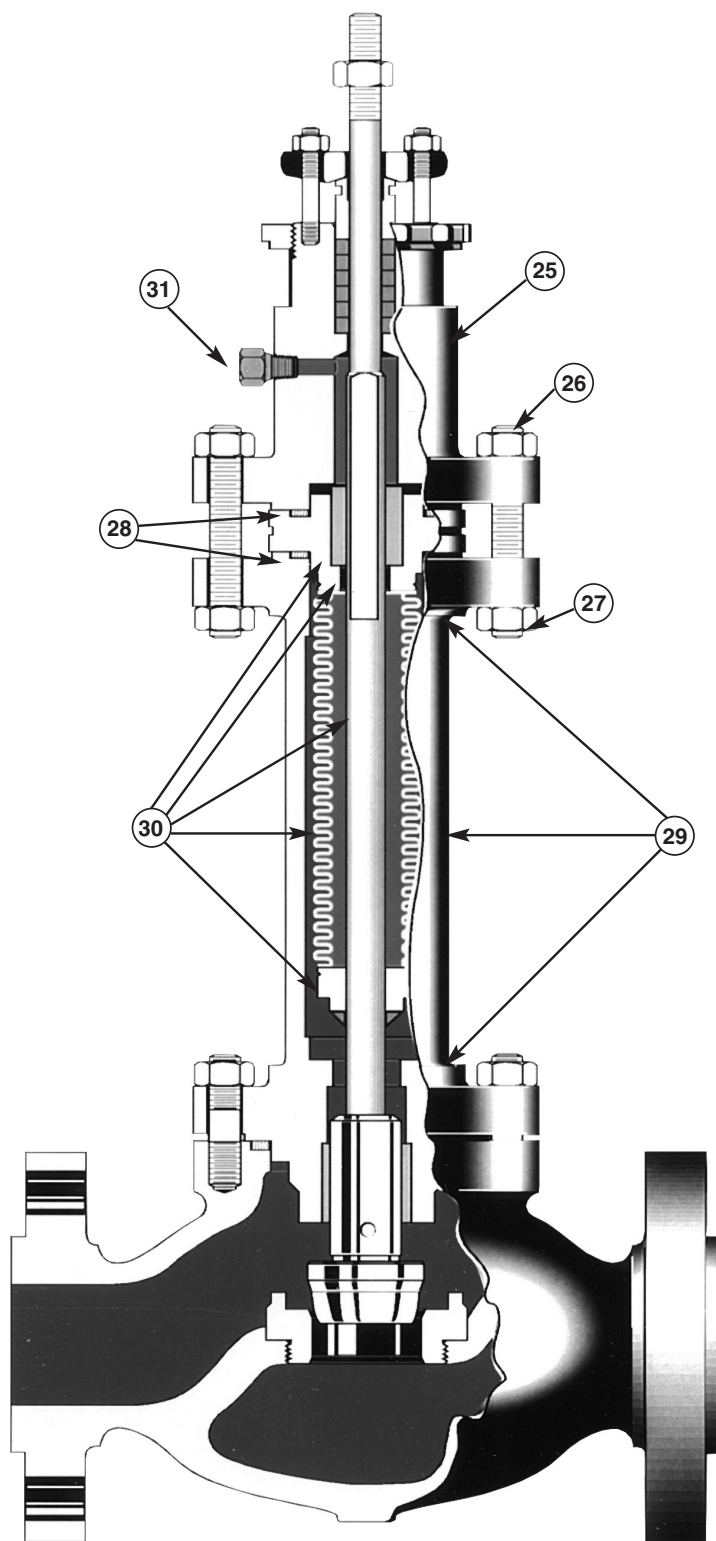

Bellows Seal Construction

Bellows Seal - Carbon Steel Body Version ⁽¹⁾

Valve Sizes: .75" to 6"

Body Ratings: ANSI Class 150 to 300

Ref. No.	Temperature Range	-20°F	800°F
Ref. No.	Description	Standard and Optional Materials	
25	Valve Bonnet	Carbon Steel ASTM A216 GR WCC or ASTM A105	
26	Bonnet Stud	304 St. St. ASTM A193 GR B7	
27	Bonnet Stud Nut	Alloy Steel ASTM A194 GR 2H	
28	Bonnet Spacer Gasket	316L St. St. w/Flexible Graphite Filler (Spiral Wound)	
29	Bonnet Extension Assembly		
	Upper Flange	Carbon Steel ASTM A216 GR WCC or ASTM A105	
	Spacer	Carbon Steel ASTM A106 GR B	
	Lower Flange	Carbon Steel ASTM A216 GR WCC	
30	Bellows and Stem Assembly	Stainless Steel Bellows	
	Stem	316 St. St. ASTM A479 TY 316	
	Guide Bushing	Nitronic 60 ASTM A479 TY21800	
	Bellows	316/316L St. St. ASTM A240/A312	
	Upper Adapter	316L St. St. ASTM A479 TY 316L	
	Lower Adapter		
30	Bellows and Stem Assembly	Hastelloy Bellows	
	Stem	Hastelloy C ASTM B574	
	Guide Bushing	Stellite 6 UNS 30006	
	Bellows	Hastelloy C276 ASTM B575/B622	
	Upper Adapter	Hastelloy C ASTM B574	
	Lower Adapter		
31	1/8" NPT Plug	300 Series Stainless Steel	
Ref. No.	Temperature Range	-29°C	427°C

- Notes:
1. Materials for other components are same as listed for Standard Carbon Steel Version.
 2. Items No. 1 and 8 in Standard Materials of Construction tables are replaced by items above.

Bellows Seal - Stainless Steel Body Version ⁽¹⁾

Ref. No.	Temperature Range	-20°F	800°F
Ref. No.	Description	Standard and Optional Materials	
25	Valve Bonnet	316 St. St. ASTM A351 GR CF8M	
29	Bonnet Extension Assembly		
	Upper Flange	316 St. St. ASTM A351 GR CF8M or ASTM A182 GR F316	
	Spacer	316 St. St. ASTM A269 TY 316	
	Lower Flange	316 St. St. ASTM A351 GR CF8M	
Ref. No.	Temperature Range	-29°C	427°C

- Notes:
1. Materials for other Bellows components are same as listed for Carbon Steel Body – Bellows Seal Version.
 2. Materials for other components are same as listed for Standard Stainless Steel Version.

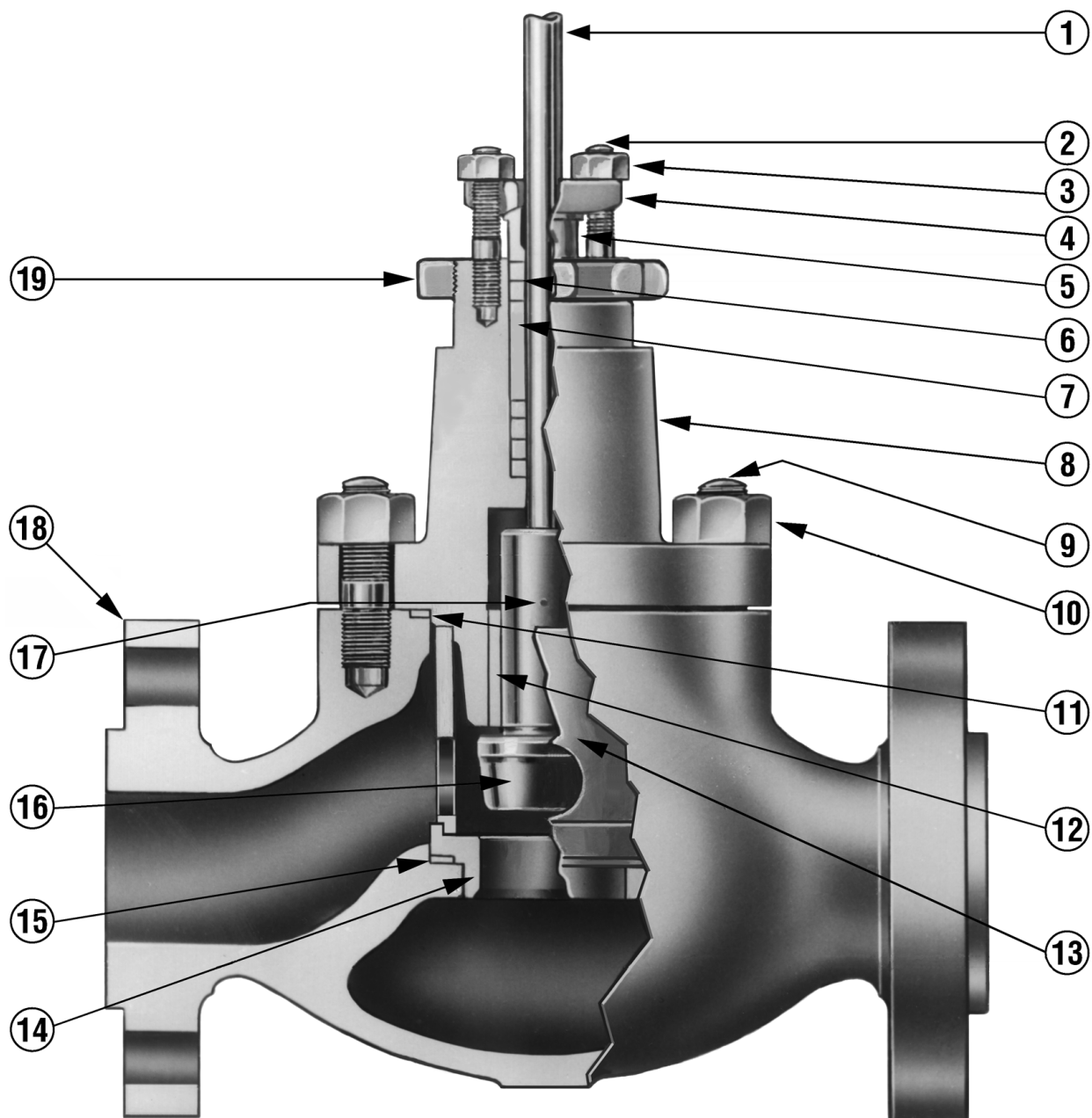

NACE⁽¹⁾ Configuration and Material Options

Valve Sizes: .75" to 6"

Body Ratings: ANSI Class 150 to 600 (4)

Ref. No.	Temperature Range	-20°F	450°F
Ref. No.	Description	Standard and Optional Materials	
1	Plug Stem	316 St. St. ASTM A479 TY 316 (HRC 22 Max.)	
2	Packing Flange Stud	304 St. St. ASTM A193 GR B8 ⁽²⁾	
		Alloy Steel ASTM A193 Gr B7M ⁽³⁾	
3	Packing Flange Nut	304 St. St. ASTM A194 GR 8 ⁽²⁾	
		Alloy Steel ASTM A194 Gr 2M ⁽³⁾	
4	Packing Flange	Carbon Steel ASTM A668 CL B	
5	Packing Follower	304 St. St. ASTM A479 TY 304	
6	Packing	Kevlar PTFE (Crane 285K)	
7	Lantern Ring (Optional)	304 St. St. ASTM A479 TY 304	
8	Valve Bonnet	Carbon Steel ASTM A216 Grade WCC (HRC 22 Max.)	
		Carbon Steel ASTM A105 (HRC 22 Max.)	
		316 St. St. ASTM A351 Gr CF8M (HRC 22 Max.)	
9	Body Stud	Alloy Steel ASTM A193 GR B7 ⁽²⁾	
		Alloy Steel ASTM A193 Gr B7M ⁽³⁾	
10	Body Stud Nut	Alloy Steel ASTM A194 GR 2H ⁽²⁾	
		Alloy Steel ASTM A194 Gr 2M ⁽³⁾	
11	Body Gasket	316L St. St. w/Flexible Graphite Filler (Spiral Wound)	
12	Guide Bushing	Stellite 6 UNS 30006	
13	Cage	304 St. St. ASTM A351 CF8 (HRC 22 Max.)	
14	Seat Ring	316 St. St. ASTM A479 TY 316 (HRC 22 Max.)	
		316 St. St. ASTM A479 TY 316 with Hardfaced Seat (HRC 22 Max.)	
15	Seat Ring Gasket	316L St. St. w/Flexible Graphite Filler (Spiral Wound)	
16	Plug	316 St. St. ASTM A479 TY 316 (HRC 22 Max.)	
		316 St. St. ASTM A479 TY 316 with Hardfaced Seat (HRC 22 Max.)	
17	Plug Pin	316 St. St. ASTM A479 TY 316 (HRC 22 Max.)	
18	Valve Body	Carbon Steel ASTM A216 Grade WCC (HRC 22 Max.)	
		316 St. St. ASTM A351 Gr CF8M (HRC 22 Max.)	
19	Drive Nut	Carbon Steel SAE 1117 ⁽²⁾	
		Carbon Steel ASTM A105 or SAE 1010-1025 ⁽³⁾	
Ref. No.	Temperature Range	-29°C	232°C

- Notes:
1. Materials and processes in accordance with the requirements of NACE specification MR0175.
 2. Materials designated for these parts conform to NACE Class III bolting requirements.
 3. Materials designated for these parts conform to NACE Class I or Class II bolting requirements.
 4. Consult Masoneilan for NACE Applications above ANSI Class 600 rating.

Dimensions (inches)

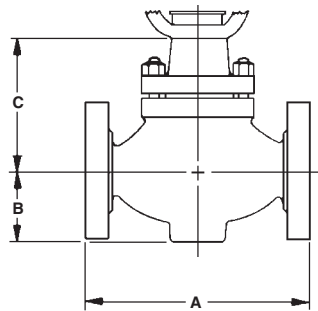

Flanged

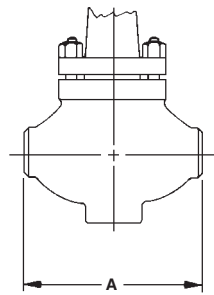

**Butt, Socket Weld
or Threaded Ends**

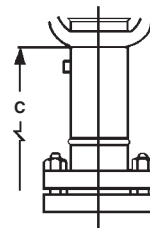

**Extension or Bellows
Bonnet**

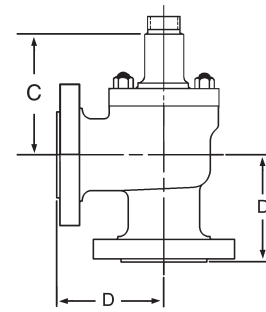

Angle

21000 Series Dimensions (inches)

ANSI Class 150 through 2500 and equivalent PN

Valve Size (inches)	A												
	ANSI Class 150-600	ANSI Class 900-1500	ANSI Class 2500	ANSI Class 150		ANSI Class 300		ANSI Class 600		ANSI Class 900-1500		ANSI Class 2500	
	BW, SW & THD	BW, SW & THD	BW, SW & THD	RF	RTJ	RF	RTJ	RF	RTJ	RF	RTJ	RF	RTJ
0.75	8.24	8.50	12.50	7.25	—	7.46	8.11	8.11	8.11	10.75	10.75	12.12	12.12
1	8.24	8.50	12.50	7.25	7.76	7.76	8.26	8.26	8.26	11.50	11.50	12.50	12.50
1.5	9.88	9.25	13.00	8.75	9.25	9.25	9.76	9.88	9.88	13.12	13.12	14.12	14.25
2	11.24	11.50	14.75	10.00	10.51	10.51	11.10	11.26	11.38	14.75	14.88	16.25	16.37
3	13.24	—	—	11.73	12.24	12.52	13.11	13.27	13.39	—	—	—	—
4	15.50	—	—	13.86	14.37	14.49	15.12	15.51	15.36	—	—	—	—
6	20.00	—	—	17.76	—	18.62	19.25	20.00	20.12	—	—	—	—

Valve Size (inches)	B				C							
	ANSI Class 150-300	ANSI Class 600	ANSI Class 900-1500	ANSI Class 2500	Standard Bonnet			Extension Bonnet			Bellows Bonnet	
	ANSI Class 150-300	ANSI Class 600	ANSI Class 900-1500	ANSI Class 2500	ANSI Class 150-600	ANSI Class 900-1500	ANSI Class 2500	ANSI Class 150-600	ANSI Class 900-1500	ANSI Class 2500	ANSI Class 150-300	
.75 & 1	2.13	2.44	2.05	2.21	5.51	7.60	7.60	9.92	10.70	10.70	16.83	
1.5	2.52	3.07	2.68	2.93	5.51	9.00	9.00	9.92	11.70	11.70	15.22	
2	3.00	3.00	3.37	3.70	5.51	9.00	10.70	9.92	11.70	12.30	15.22	
3	3.70	4.50	—	—	8.00	—	—	13.90	—	—	23.87	
4	4.61	5.51	—	—	8.07	—	—	15.87	—	—	23.87	
6	5.90	7.36	—	—	11.18	—	—	16.69	—	—	29.76	

Valve Size (inches)	D												
	ANSI Class 150-600	ANSI Class 900-1500	ANSI Class 2500	ANSI Class 150		ANSI Class 300		ANSI Class 600		ANSI Class 900-1500		ANSI Class 2500	
	BW, SW & THD	BW, SW & THD	BW, SW & THD	RF	RTJ	RF	RTJ	RF	RTJ	RF	RTJ	RF	RTJ
0.75	4.13	4.25	6.25	3.62	—	3.88	4.13	4.13	4.13	5.38	5.38	6.06	6.06
1	4.13	4.25	6.25	3.62	—	3.88	4.13	4.13	4.13	5.75	5.75	6.25	6.25
1.5	4.94	4.63	6.50	4.37	—	4.62	4.88	4.94	4.94	6.56	6.56	7.06	7.12
2	5.62	5.57	7.38	5.00	—	5.25	5.56	5.62	5.69	7.38	7.44	8.13	8.19
3	6.62	—	—	5.88	—	6.25	6.56	6.62	6.69	—	—	—	—
4	7.75	—	—	6.94	—	7.25	7.56	7.75	7.81	—	—	—	—
6	10.00	—	—	8.88	—	9.31	9.62	10.00	10.06	—	—	—	—

Dimensions (mm)

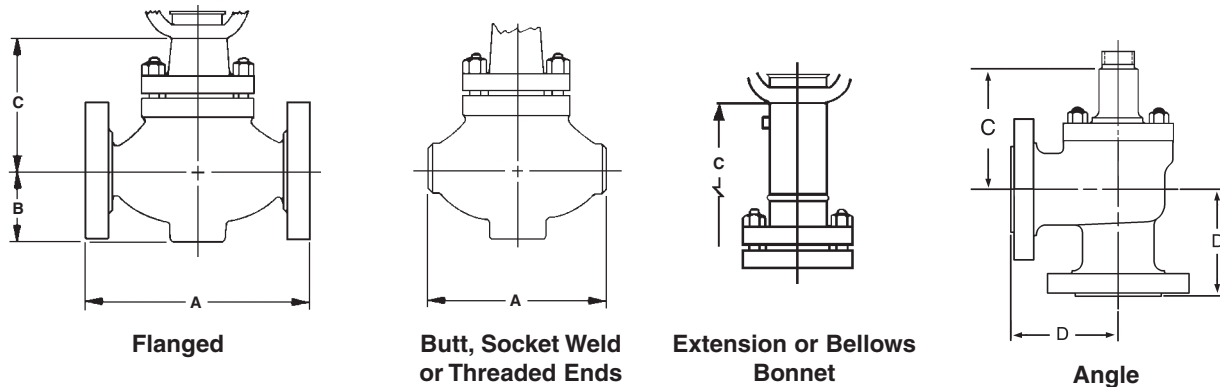

21000 Series Dimensions (mm)

ANSI Class 150 through 2500 and equivalent PN

Valve Size (mm)	A															
	ANSI Class 150-600		ANSI Class 900-1500		ANSI Class 2500		ANSI Class 150		ANSI Class 300		ANSI Class 600		ANSI Class 900-1500		ANSI Class 2500	
	BW, SW & THD	BW, SW & THD	BW, SW & THD	RF	RTJ	RF	RTJ	RF	RTJ	RF	RTJ	RF	RTJ	RF	RTJ	
20	209	216	318	184	—	189	206	206	206	273	273	308	308			
25	209	216	318	184	197	197	210	210	210	292	292	318	318			
40	251	235	330	222	235	235	248	251	251	333	333	359	362			
50	285	292	375	254	267	267	282	286	289	375	378	413	416			
80	336	—	—	298	311	318	333	337	340	—	—	—	—			
100	394	—	—	352	365	368	384	394	390	—	—	—	—			
150	508	—	—	451	—	473	489	508	511	—	—	—	—			

Valve Size (mm)	B				C							
	ANSI Class 150-300	ANSI Class 600	ANSI Class 900-1500	ANSI Class 2500	Standard Bonnet			Extension Bonnet			Bellows Bonnet	
					ANSI Class 150-600	ANSI Class 900-1500	ANSI Class 2500	ANSI Class 150-600	ANSI Class 900-1500	ANSI Class 2500	ANSI Class 150-300	
20 & 25	54	62	52	56	140	193	193	252	272	272	427	
40	64	78	68	74	140	229	229	252	297	297	387	
50	76	76	86	94	140	229	272	252	297	312	387	
80	94	114	—	—	203	—	—	353	—	—	606	
100	117	140	—	—	205	—	—	403	—	—	606	
150	150	187	—	—	284	—	—	424	—	—	756	

Valve Size (mm)	D															
	ANSI Class 150-600		ANSI Class 900-1500		ANSI Class 2500		ANSI Class 150		ANSI Class 300		ANSI Class 600		ANSI Class 900-1500		ANSI Class 2500	
	BW, SW & THD	BW, SW & THD	BW, SW & THD	RF	RTJ	RF	RTJ	RF	RTJ	RF	RTJ	RF	RTJ	RF	RTJ	
20	105	108	159	92	—	99	105	105	105	137	137	154	154			
25	105	108	159	92	—	99	105	105	105	146	146	159	159			
40	125	118	165	111	—	117	124	125	125	167	167	179	181			
50	143	141	187	127	—	133	141	143	145	187	189	207	208			
80	168	—	—	149	—	159	167	168	170	—	—	—	—			
100	197	—	—	176	—	184	192	197	198	—	—	—	—			
150	254	—	—	226	—	236	244	254	256	—	—	—	—			

Dimensions

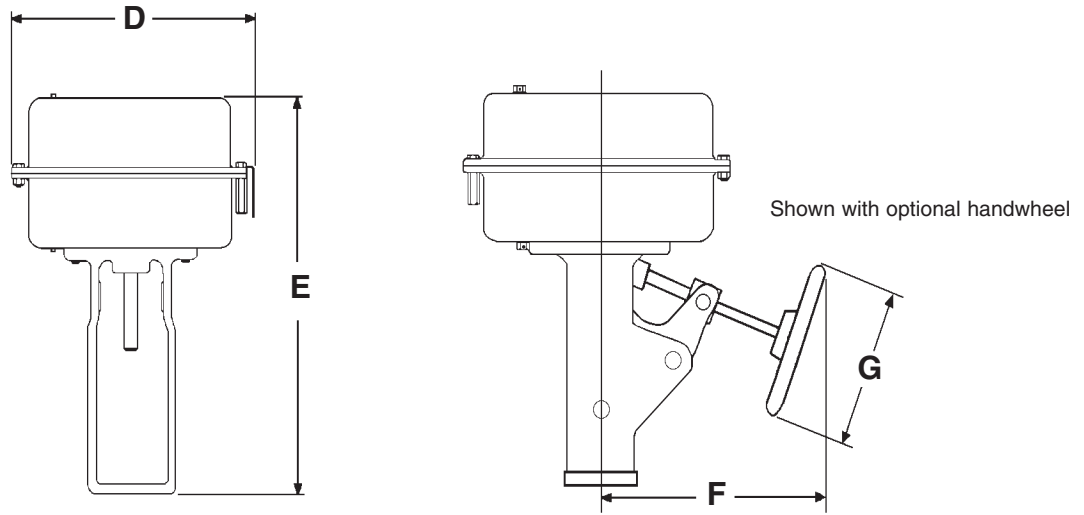

Model 87/88 Actuator (inches)

Actuator Size	D	E	F	G
3	9.00	11.00	6.73	6.30
6	11.49	15.54	10.00	9.00
10	14.50	19.58	10.90	12.00
16	18.75	28.22	14.00	18.00
23	21.63	30.71	16.00	18.00

Actuator removal clearance = 6 inches

Model 87/88 Actuator (mm)

Actuator Size	D	E	F	G
3	230	279	171	160
6	292	395	254	229
10	368	497	277	305
16	476	717	356	457
23	549	780	406	457

Actuator removal clearance = 150 mm

Weights

Body S/A (lbs)

Valve Size (inches)	ANSI Class 150 – 300		ANSI Class 600		ANSI Class 900 – 1500		ANSI Class 2500	
	FLG	BW, SW & THD	FLG	BW, SW & THD	FLG	BW, SW & THD	FLG	BW, SW & THD
0.75	36	27	38	27	57	44	70	44
1	36	27	38	27	75	44	90	44
1.5	49	36	53	36	100	57	118	57
2	57	44	64	44	144	82	255	154
3	127	73	128	99	—	—	—	—
4	196	121	216	135	—	—	—	—
6	355	238	450	272	—	—	—	—

Body S/A (kg)

Valve Size (mm)	ANSI Class 150 – 300		ANSI Class 600		ANSI Class 900 – 1500		ANSI Class 2500	
	FLG	BW, SW & THD	FLG	BW, SW & THD	FLG	BW, SW & THD	FLG	BW, SW & THD
20	16	12	17	12	26	20	32	20
25	16	12	17	12	34	20	41	20
40	22	16	24	16	45	26	53	26
50	26	20	29	20	65	37	116	70
80	58	33	58	45	—	—	—	—
100	89	55	98	61	—	—	—	—
150	161	108	204	123	—	—	—	—

Actuator Weights (lbs)

Actuator Size	Standard	with Handwheel
3	27	33
6	45	60
10	85	105
16	210	245
23	265	340

Actuator Weights (kg)

Actuator Size	Standard	with Handwheel
3	12	15
6	20	27
10	38	48
16	95	111
23	120	154

Body/Actuator Volume (cu.ft)

Valve Size (inches)	ANSI Class 150 to 2500 and equivalent PN
.75	10.0
1	10.0
1.5	10.0
2	10.0
3	22.0
4	22.0
6	22.0

Body/Actuator Volume (dm³)

Valve Size (mm)	ANSI Class 150 to 2500 and equivalent PN
20	283
25	283
40	283
50	283
80	623
100	623
150	623

Bellows Seal Assembly

Valve Size		Estimated Additional Weight	
inches	mm	lbs	kg
.75 to 2	20 to 50	18	8
3 & 4	80 & 100	35	16
6	150	75	33

Accessories

Options

Extension Bonnets
Environmental Capabilities (LE Packing)
Lubricator & Isolation Valve
Other Flange Facings
Limit Stops
Body Drain Plug
Reducer and Nipple Connections
NACE Compliance
Custom Trim Materials
U.O.P. Trim Materials
Other Materials
Non-Destructive Examination
Oxygen Cleaning
Electric Actuators

**For additional Accessories and Options,
consult Masoneilan.**

AUSTRIA
Dresser Valves Europe GmbH
Kaiserlallee 14
A-2100 Korneuburg (near Wien), Austria
Phone: 43-2262-63689
Fax: 43-2263-6368915

BELGIUM
Dresser Europe S.p.r.L.
281-283 Chaussée de Bruxelles
281-283 Brusselsesteenweg
1190 Brussels, Belgium
Phone: 32-2-344-0970
Fax: 32-2-344-1123

BRAZIL
Dresser Industria E Comercio Ltda
Divisao Masoneilan
Rua Senador Vergueiro, 433
09521-320 Sao Caetano Do Sul
Sao Paulo, Brazil
Phone: 55-11-453-5511
Fax: 55-11-453-5565

CANADA
Alberta
Dresser - Masoneilan
DI Canada, Inc.
Suite 1300, 311-6th Ave., S.W.
Calgary, Alberta T2P 3H2
Canada
Phone: 403-290-0001
Fax: 403-290-1526

Ontario
Dresser - Masoneilan
DI Canada, Inc.
5010 North Service Road
Burlington, Ontario L7L 5R5
Canada
Phone: 905-335-3529
Fax: 905-336-7628

CHINA
Dresser
Suite 2403, Capital Mansion
6 Xinyuannan Road
Chao Yang district
Beijing 100040
Phone: 86-10-6466-1164
Fax: 86-10-6466-0195

FRANCE
Dresser Produits Industriels S.A.S.
Division Masoneilan
4, place de Saverne
92400 Courbevoie
France
Phone: 33-1-49-04-90-00
Fax: 33-1-49-04-90-10

GERMANY
Dresser Valves Europe GmbH
Heiligenstrasse 75
41751 Viersen (Dulken) Germany
Phone: 49-2162-81-70-0
Fax: 49-2162-81-70-200

INDIA
Dresser Valve India Pvt. Ltd.
305/306 "Midas" - Sahar Plaza
Mathurdas Vasanji Road
J.B. Nagar - Andheri East
Mumbai, India 400 059
Phone: 91-22-835-4790
Fax: 91-22-835-4791

ITALY
Dresser Italia S.r.L.
Masoneilan Operation
Via Cassano, 77
80020 Casavatore (Naples), Italy
Phone: 39-81-7892-111
Fax: 39-81-7892-208

JAPAN
Niigata Masoneilan Company, Ltd.
20th Floor, Marive East Tower
WBG 2-6 Nakase, Mihama-Ku
Chiba-shi, Chiba 261-7120, Japan
Phone: 81-43-297-9222
Fax: 81-43-299-1115

KOREA
Dresser Korea, Inc.
#2107 Kuk Dong Building
60-1, 3-Ka, Choongmu-ro
Chung-Ku, Soeul, 100705
Phone: 82-2-274-0792
Fax: 82-2-274-0794

KUWAIT
Dresser Flow Control
10th Floor, Al-Rashed Complex
Fahad Salam Street
P.O. Box 242, Safat 13003
Phone: 00965-9061157
Fax: 00965-3718590

MALAYSIA
Dresser Flow Control - Far East
Business Suite 19A-9-1
Level 9, UOA Centre
No. 19 Jalan Pinang
50450 Kuala Lumpur, Malaysia
Phone: 60-3-2163-2322
Fax: 60-3-2163-6312

MEXICO
Dresser Valve de Mexico, S.A. de C.V.
Henry Ford No. 114, Esq. Fulton
Fraccionamiento Industrial San Nicolas
54030 Tlalnepantla Estado de Mexico
Phone: 52-5-310-9863
Fax: 52-5-310-5584

THE NETHERLANDS
Dresser Valves Europe
Steenhouwerstraat 11
3194 AG Hoogvliet
The Netherlands
Mailing Address:
P.O. Box 640
NL3190 AN Hoogvliet RT
The Netherlands
Phone: 31-10-438-4122
Fax: 31-10-438-4443

SAUDI ARABIA
Dresser Al Rushaid
Valve & Instrument Company
P.O. Box 10145
Jubail Industrial City 31961
Saudi Arabia
Phone: +966-3-341-0278
Fax: +966-3-341-0696

SINGAPORE
Dresser Singapore, Pte. Ltd.
16, Tuas Avenue 8
Singapore 639231
Phone: 65-6-861-6100
Fax: 65-6-861-7172

SOUTH AFRICA
Dresser Ltd., South Africa Branch
P.O. Box 2234, 16 Edendale Road
Eastleigh, Edenvale 1610
Republic of South Africa
Phone: 27-11-452-1550
Fax: 27-11-452-6542

SPAIN
Masoneilan S.A.
C/ Murcia 39 C
08830 Sant Boi de Llobregat
Barcelona, Spain
Phone: 34-93-652-6430
Fax: 34-93-652-6444

SWITZERLAND
Dresser Valves Europe SA
Fraentalweg 76
CH-8045 Zurich, Switzerland
Mailing Address:
P.O. Box 3568
CH-8021 Zurich, Switzerland
Phone: 41-1-450 28 91
Fax: 41-1-450 28 95

UNITED ARAB EMIRATES
Dresser
Middle East Operations
Post Box 61302 (mail)
R/A 8, Units JA01/JA02 (courier)
Jebel Ali Free Zone
United Arab Emirates
Phone: 971-4-8838-752
Fax: 971-4-8838-038

Sales Offices and Distribution Centers

UNITED KINGDOM
DI U.K. Limited
Trevithick Works
Gillibrands Estate, Skelmersdale
Lancashire WN8 9TU, England
United Kingdom
Phone: 44-1695-52600
Fax: 44-1695-52662

DI U.K.
Unit 4, Suite 1.1, Nobel House
Grand Union Office Park
Packet Boat Lane, Uxbridge
Middlesex UB8 2GH, England
United Kingdom
Phone: 44-1895-454900
Fax: 44-1895-454919

UNITED STATES
Northern Region
Dresser - Masoneilan
85 Bodwell Street
Avon, MA 02322-1190
Phone: 508-586-4600
Fax: 508-427-8971

Southern Region
Dresser - Masoneilan
2135 Highway 6 South
Houston, TX 77077
Phone: 281-496-8100
Toll Free: 800-847-1099
Fax: 281-596-4222

South Texas Operations
Dresser - Masoneilan
4841 Leopard Street
Corpus Christi, TX 78408-2621
Phone: 361-877-2414
Fax: 361-584-1196

Masoneilan Aftermarket
Sales & Service Center
16030 Bear Bayou Drive
Channelview, TX 77530
Phone: 281-862-1500
Fax: 281-862-1550

Western Region
Dresser - Masoneilan
Masoneilan
2950 East Birch Street
Brea, CA 92821
Phone: 714-572-1528
Fax: 714-572-1463

