

# Y690A Series Pressure Reducing Regulators

## Introduction

The Y690A Series self-contained, spring-loaded regulators (figure 1) provide economical pressure reducing control in a variety of commercial and industrial applications. The Y690A Series design is ideally suited to control gas supply to in-plant processing equipment. The rugged casings and sliding pusher post design withstand the full 150 psig (10,3 bar) inlet pressure at both the inlet and outlet connections. The sliding pusher post design prevents damage to internal parts if the downstream pressure exceeds the setpoint. Because these regulators can withstand the full inlet pressure, a downstream or internal relief valve is not required to protect the downstream side of the regulator.

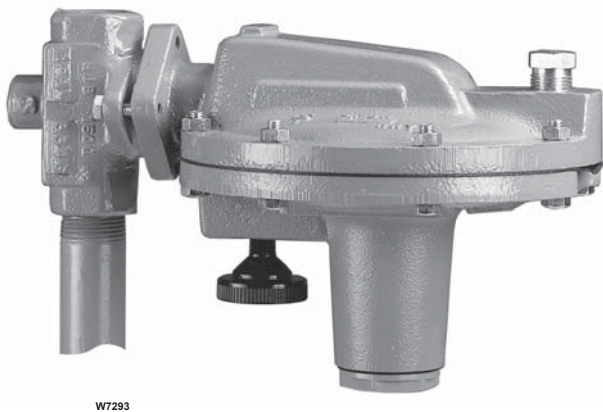

TYPE Y690A



TYPE Y690AH

Figure 1. Y690A Series Direct-Operated Pressure Reducing Regulators

## Features

€ **Easy Conversion Between Constructions**—Converts easily from the Type Y690A to the Type Y690AM with two O-rings and one machine screw.

€ **Sour Gas Service Capability**—For sour gas applications, the Y690A Series regulators are available in materials that comply with National Association of Corrosion Engineers (NACE) Standard MR0175-92.

€ **Inlet Pressure Equals Outlet Pressure**—Full inlet pressure capability on the downstream side of the regulator.

€ **Corrosion Resistance**—Multiple regulator constructions are available in a variety of materials for compatibility with corrosive process gases.

€ **Multiple Applications**—The Y690A Series can be used for a wide variety of gases including air, nitrogen, natural gas, sour gas, butane, and propane.



## Specifications

### Available Configurations

**Type Y690A:** Direct-operated pressure reducing regulator for outlet pressures up to 7-inches w.c. (17 mbar) equipped with a pitot tube for greater regulated capacities.

**Type Y690AH:** Direct-operated pressure reducing regulator for outlet pressures up to 7 psig (483 mbar) equipped with a pitot tube for greater regulated capacities.

**Type Y690AM:** Direct-operated pressure reducing regulator for outlet pressures up to 7-inches w.c. (17 mbar) equipped with a blocked throat and O-ring stem seal. The lower diaphragm casing is tapped 1/2-inch NPT screwed for control line connection.

**Type Y690AHM:** Direct-operated pressure reducing regulator for outlet pressures up to 7 psig (483 mbar) equipped with a blocked throat and O-ring stem seal. The lower diaphragm casing is tapped 1/2-inch NPT for control line connection.

### Body Sizes

3/4 (DN 20) or 1-inch (DN 25)

### End Connection Styles

See table 2

### Maximum Allowable Inlet Pressure<sup>(1)</sup>

150 psig (10,3 bar)

### Maximum Operating Inlet Pressure<sup>(1)</sup>

See table 5

### Maximum Outlet Pressure (Casing)<sup>(1)</sup>

150 psig (10,3 bar)

### Maximum Emergency Outlet Pressure to Avoid Internal Parts Damage<sup>(1)</sup>

150 psig (10,3 bar)

### Outlet Pressure Ranges<sup>(1)</sup>

See table 6

### Orifice Sizes and Flow Coefficients

See table 3

### Flow Capacities

See tables 7 and 8

### Construction Materials

See table 4

### Material Temperature Capabilities<sup>(1)</sup>

**Nitrile (NBR):** -20° to 180°F (-29° to 82°C)

**Fluoroelastomer (FKM):**  
40° to 300°F (4° to 149°C)

**Ethylene propylene (EPDM):**  
-20° to 300°F (-29° to 149°C)

**Perfluoroelastomer (FFKM):**  
-20° to 300°F (-29° to 149°C)

### Pressure Setting Adjustment

Adjusting Screw

### Spring Case Connection

1/4-inch NPT Screwed

### Diaphragm Case Connection

1/2-inch NPT Screwed

### Approximate Weight

19 pounds (8,6 kg)

1. The pressure/temperature limits in this bulletin and any applicable standard or code limitation should not be exceeded.

**Table 2. End Connection Styles**

BODY SIZE, INCHES (DN)	END CONNECTION STYLES		
	Ductile Iron	Stainless Steel <sup>(1)</sup>	Hastelloy C
3/4 (20) or 1 (25)	NPT Screwed	NPT Screwed, SWE, ANSI Class 150 RF, ANSI Class 300 RF, or PN 16/25/40	150 RF (1-inch only)
1. All flanges are welded on except Hastelloy C. Weld-on flange dimension is 14-inches (356 mm) face-to-face.			

**Table 3. Orifice Sizes and Flow Coefficients**

ORIFICE SIZE, INCHES (mm)	WIDE-OPEN C <sub>g</sub> FOR RELIEF VALVE SIZING	WIDE-OPEN C <sub>v</sub> FOR RELIEF VALVE SIZING	C <sub>1</sub>
1/8 (3,2)	12.3	0.35	35
1/4 (6,4)	50	1.43	
3/8 (9,5)	110	3.14	
1/2 (12,7)	200	5.71	
9/16 (14,3)	250	7.14	

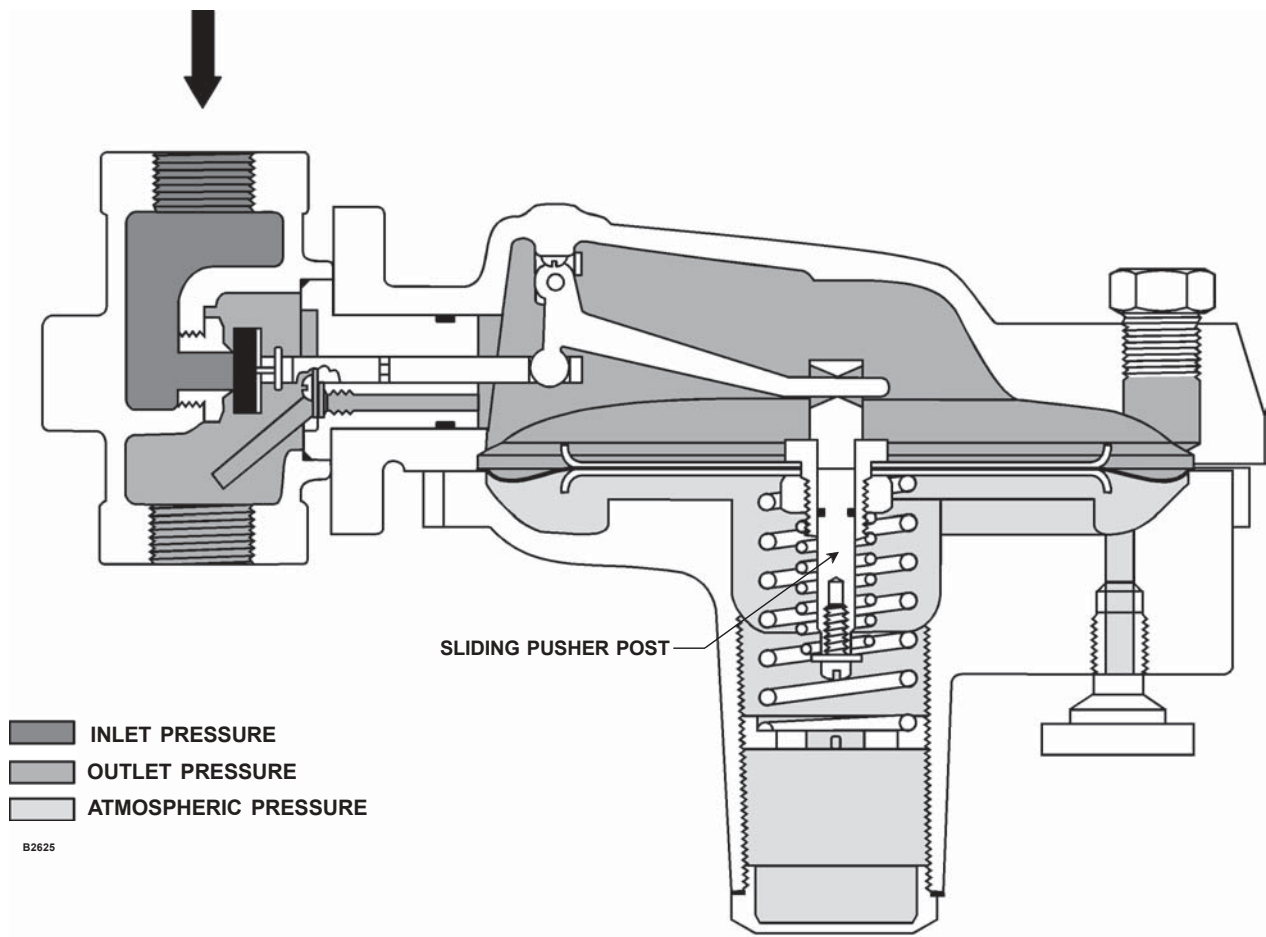

Figure 2. Y690A Series Operational Schematic

## Product Description

### Y690A Series Pressure Reducing Regulators

Very low-pressure (Types Y690A and Y690AM) and higher-pressure versions (Types Y690AH and Y690AHM) are available for operating inlet pressures to 150 psig (10,3 bar) and outlet pressures settings from 1-inch w.c. to 7 psig (2,5 mbar to 0,5 bar). Refer to table 6 for outlet pressure ranges of each type. These regulators are available in 3/4-inch (DN 20) and 1-inch (DN 25) body sizes with the end connections as shown in table 2.

### Downstream Control Line

The Types Y690AM and Y690AHM regulators have a blocked throat stem seal with O-rings and a 1/2-inch NPT

screwed control line connection in the diaphragm case. It is used for monitoring applications or other applications where additional equipment is installed between the regulator and the pressure control point. The stem seal separates the body outlet pressure from the diaphragm case.

### Sliding Pusher Post

The diaphragm assembly of the regulator is equipped with a sliding pusher post. During an overpressure situation (outlet pressure above setpoint or lockup pressure), the spring of the sliding pusher post is compressed, allowing the diaphragm head to come to rest on the spring case. This action prevents any damage to internal parts.

# Bulletin 71.1:Y690A

**Table 4. Construction Materials**

BODY	DIAPHRAGM CASE	SPRING CASE	TRIM	DIAPHRAGM	DISK
Ductile iron, CF8M Stainless steel, or Hastelloy C	Ductile iron, CF8M Stainless steel, or Hastelloy C	Ductile iron or CF8M Stainless steel	S30300 Stainless steel, S31600 Stainless steel, or Hastelloy C	Nitrile (NBR), Fluoroelastomer (FKM), or PTFE bonded nitrile	Nitrile (NBR), Fluoroelastomer (FKM), Perfluoroelastomer (FFKM), Teflon (PTFE), or Ethylenepropylene (EPDM)

**Table 5. Maximum Operating Inlet Pressures**

ORIFICE SIZE, INCHES (mm)	OUTLET PRESSURE RANGE, PSIG (bar)							
	Type Y690A		Types Y690AH and Y690AM					
	1 to 2-1/2-Inches w.c. (2,5 to 6,0 mbar)	2-1/2 to 7-Inches w.c. (6,0 to 17 mbar)	5 to 10-Inches w.c. (12 to 25 mbar)	7 to 15-Inches w.c. (17 to 37 mbar)	0.5 to 1.2 Psig (34 to 83 mbar)	1.2 to 2.5 Psig (83 to 172 mbar)	2.5 to 4.5 Psig (0,17 to 0,31 bar)	4.5 to 7 Psig (0,31 to 0,48 bar)
1/8 (3,2)	150 (10,3)	150 (10,3)	150 (10,3)	150 (10,3)	150 (10,3)	150 (10,3)	150 (10,3)	150 (10,3)
1/4 (6,4)	40 (2,8)	60 (4,1)	75 (5,2)	75 (5,2)	75 (5,2)	150 (10,3)	150 (10,3)	150 (10,3)
3/8 (9,5)	20 (1,4)	20 (1,4)	35 (2,4)	35 (2,4)	35 (2,4)	60 (4,1)	60 (4,1)	60 (4,1)
1/2 (12,7)	10 (0,69)	10 (0,69)	8 (0,55)	8 (0,55)	8 (0,55)	10 (0,69)	12 (0,83)	12 (0,83)
9/16 (14,3)	5 (0,34)	5 (0,34)	5 (0,34)	5 (0,34)	5 (0,34)	6 (0,41)	8 (0,55)	8 (0,55)

**Table 6. Outlet Pressures and Spring Part Numbers**

TYPE	OUTLET CONTROL PRESSURE RANGE	SPRING PART NUMBER	SPRING COLOR	SPRING WIRE DIAMETER
Y690A and Y690AM	1 to 2-1/2-inches w.c. (2 to 6 mbar)	1B558527052 <sup>(1)(2)</sup>	Orange	0.072-inch (1,83 mm)
	2-1/2 to 7-inches w.c. (6 to 17 mbar)	1B653827052 <sup>(1)</sup>	Red	0.085-inch (2,16 mm)
Y690AH and Y690AHM	5 to 10-inches w.c. (12 to 25 mbar)	1B653827052	Red	0.085-inch (2,2 mm)
	7 to 15-inches w.c. (17 to 37 mbar)	1B653927022	Olive drab	0.105-inch (2,7 mm)
	0.5 to 1.2 psig (34 to 83 mbar)	1B537027052	Yellow	0.114-inch (2,9 mm)
	1.2 to 2.5 psig (83 to 172 mbar)	1B537127022	Light green	0.156-inch (4,0 mm)
	2.5 to 4.5 psig (0,17 to 0,31 bar)	1B537227022	Light blue	0.187-inch (4,8 mm)
	4.5 to 7 psig (0,31 to 0,48 bar)	1B537327052	Black	0.218-inch (5,5 mm)

1. To achieve the published outlet pressure range the spring case must be installed pointing down.  
2. Do not use fluoroelastomer (FKM) diaphragm with this spring at diaphragm temperatures lower than 60°F (16°C).

## Capacity Information

Tables 7 and 8 give the regulating capacities of the Y690A Series regulators at selected inlet pressures and outlet pressure settings. Flows are in scfh (60°F and 14.7 psia) of 1.0 specific gravity air at 60°F. For gases of other specific gravities, divide the given capacity by the square root of the appropriate specific gravity of the gas required. Then, if capacity is desired in normal cubic meters per hour at 0°C and 1,01325 bar, multiply scfh by 0.0268. To determine wide-open flow capacities for relief sizing, use the following formula:

$$Q = \sqrt{\frac{520}{GT}} C_g P_i \sin \left[ \frac{3417}{C_1} \sqrt{\frac{\Delta P}{P_1}} \right] \text{ Deg}$$

where,

- $C_g$  = gas sizing coefficient from table 1
- $C_1 = C_g / C_v$ , or 35 from table 1
- $G$  = gas specific gravity (air = 1.0)
- $P_{1abs}$  = inlet pressure, psia (add 14.7 psi to gauge inlet pressure to obtain absolute inlet pressure)
- $Q$  = flow rate, scfh
- $T$  = absolute temperature in °Rankine of gas at inlet

**Table 7. Types Y690A and Y690AM Capacities**

BODY SIZE, INCHES (DN)	OUTLET PRESSURE RANGE, PART NUMBER, AND COLOR	OUTLET PRESSURE SETTING	INLET PRESSURE, PSIG (bar)	CAPACITIES IN SCFH (m <sup>3</sup> /h(n)) OF AIR <sup>(1)</sup>				
				Orifice Size, Inches (mm)				
				1/8 (3,2)	1/4 (6,4)	3/8 (9,5)	1/2 (12,7)	9/16 (14,3)
3/4 (20)	1 to 2-1/2-inches w.c. (2,5 to 6,2 mbar)  1B558527052 Orange	1-inch w.c. (2,5 mbar)	2 (0,14)	120 (3,22)	300 (8,04)	350 (9,38)	460 (12,3)	600 (16,1)
			5 (0,34)	180 (4,82)	410 (11,0)	450 (12,1)	600 (16,1)	700 (18,8)
			10 (0,69)	200 (5,36)	510 (13,7)	530 (14,2)	800 (21,4)	
			20 (1,4)	280 (7,50)	610 (16,3)	650 (17,4)		
			40 (2,8)	600 (16,1)	970 (26,0)			
			60 (4,1)	800 (21,4)				
		80 (5,5)	900 (24,1)					
		100 (6,9)	1000 (26,8)					
		125 (8,6)	1200 (32,2)					
		150 (10,3)	1300 (34,8)					
		2-1/2-inches w.c. (6,2 mbar)	2 (0,14)	120 (3,22)	350 (9,38)	400 (10,7)	640 (17,2)	770 (20,6)
		5 (0,34)	200 (5,36)	500 (13,4)	600 (16,1)	820 (22,0)	950 (25,5)	
	10 (0,69)	220 (5,90)	660 (17,7)	750 (20,1)	1020 (27,3)			
	20 (1,4)	280 (7,50)	770 (20,6)	950 (25,5)				
	40 (2,8)	650 (17,4)	1020 (27,3)					
	60 (4,1)	900 (24,1)						
	80 (5,5)	1050 (28,1)						
	100 (6,9)	1150 (30,8)						
	125 (8,6)	1200 (32,2)						
	150 (10,3)	1250 (33,5)						
	2-1/2 to 7-inches w.c. (6,2 to 17 mbar)  1B653827052 Red	2-1/2-inches w.c. (6,2 mbar)	2 (0,14)	120 (3,22)	200 (5,36)	230 (6,16)	450 (12,1)	490 (13,1)
			5 (0,34)	180 (4,82)	270 (7,24)	530 (14,2)	600 (16,1)	680 (18,2)
			10 (0,69)	230 (6,16)	450 (12,1)	700 (18,8)	810 (21,7)	
			20 (1,4)	250 (6,70)	630 (16,9)	900 (24,1)		
40 (2,8)			600 (16,1)	870 (23,3)				
60 (4,1)			780 (20,9)	1250 (33,5)				
80 (5,5)		950 (25,5)						
100 (6,9)		1010 (27,1)						
125 (8,6)		1150 (30,8)						
150 (10,3)		1210 (32,4)						
3-inches w.c. (7,5 mbar)		2 (0,14)	110 (2,95)	190 (5,09)	230 (6,16)	420 (11,3)	460 (12,3)	
5 (0,34)		130 (3,48)	270 (7,24)	500 (13,4)	610 (16,3)	680 (18,2)		
10 (0,69)	190 (5,09)	450 (12,1)	700 (18,8)	790 (21,2)				
20 (1,4)	250 (6,70)	630 (16,9)	900 (24,1)					
40 (2,8)	580 (15,5)	860 (23,0)						
60 (4,1)	710 (19,0)	1050 (28,1)						
80 (5,5)	990 (26,5)							
100 (6,9)	1130 (30,3)							
125 (8,6)	1280 (34,3)							
150 (10,3)	1330 (35,6)							
7-inches w.c. (17 mbar)	2 (0,14)	120 (3,22)	160 (4,39)	190 (5,09)	310 (8,31)	400 (10,7)		
5 (0,34)	190 (5,09)	220 (5,90)	440 (11,8)	520 (13,9)	600 (16,1)			
10 (0,69)	200 (5,36)	400 (10,7)	660 (17,7)	760 (20,4)				
20 (1,4)	220 (5,90)	540 (14,5)	940 (25,2)					
40 (2,8)	490 (13,1)	720 (19,3)						
60 (4,1)	600 (16,1)	1000 (26,8)						
80 (5,5)	670 (18,0)							
100 (6,9)	790 (21,2)							
125 (8,6)	840 (22,5)							
150 (10,3)	1060 (28,4)							

Shaded areas indicate maximum allowable inlet pressure is exceeded.

1. Deviation from setpoint is -1 to +2-inches w.c (-2,5 to +5 mbar).

# Bulletin 71.1:Y690A

Table 7. Types Y690A and Y690AM Capacities (continued)

BODY SIZE, INCHES (DN)	OUTLET PRESSURE RANGE, PART NUMBER, AND COLOR	OUTLET PRESSURE SETTING	INLET PRESSURE, PSIG (bar)	CAPACITIES IN SCFH (m <sup>3</sup> /h(n)) OF AIR <sup>(1)</sup>				
				Orifice Size, Inches (mm)				
				1/8 (3,2)	1/4 (6,4)	3/8 (9,5)	1/2 (12,7)	9/16 (14,3)
1 (25)	1 to 2-1/2-inches w.c. (2,5 to 6,2 mbar)  1B558527052 Orange	1-inch w.c. (2,5 mbar)	2 (0,14)	110 (2,95)	310 (8,31)	460 (12,3)	480 (12,9)	950 (25,5)
			5 (0,34)	190 (5,09)	350 (9,38)	990 (26,5)	1100 (29,5)	1140 (30,6)
			10 (0,69)	240 (6,43)	800 (21,4)	1120 (30,0)	1520 (40,7)	
			20 (1,4)	350 (9,38)	930 (24,9)	1320 (35,4)		
			40 (2,8)	650 (17,4)	1120 (30,0)			
			60 (4,1)	960 (25,7)				
		80 (5,5)	1170 (31,4)					
		100 (6,9)	1300 (34,8)					
		125 (8,6)	1370 (36,7)					
		150 (10,3)	1420 (38,1)					
		2-1/2-inches w.c. (6,2 mbar)	2 (0,14)	120 (3,22)	290 (7,77)	340 (9,11)	470 (12,6)	790 (21,2)
			5 (0,34)	200 (5,36)	350 (9,38)	740 (19,8)	930 (24,9)	1140 (30,6)
	10 (0,69)		240 (6,43)	740 (19,8)	940 (25,2)	1240 (33,2)		
	20 (1,4)		350 (9,38)	900 (24,1)	1250 (33,5)			
	40 (2,8)		600 (16,1)	1230 (33,0)				
	60 (4,1)		940 (25,2)					
	2-1/2 to 7-inches w.c. (6,2 to 17 mbar)  1B653827052 Red	2-1/2-inches w.c. (6,2 mbar)	2 (0,14)	110 (2,95)	130 (3,48)	270 (7,24)	470 (12,6)	630 (16,9)
			5 (0,34)	180 (4,82)	300 (8,04)	590 (15,8)	760 (20,4)	860 (23,0)
			10 (0,69)	260 (6,97)	600 (16,1)	800 (21,4)	1080 (28,9)	
			20 (1,4)	320 (8,58)	660 (17,7)	1140 (30,6)		
			40 (2,8)	580 (15,5)	970 (26,0)			
			60 (4,1)	880 (23,6)	1300 (34,8)			
		3-inches w.c. (7,5 mbar)	80 (5,5)	1010 (27,1)				
			100 (6,9)	1200 (32,2)				
125 (8,6)			1280 (34,3)					
150 (10,3)			1400 (37,5)					
2 (0,14)			100 (2,68)	150 (4,02)	200 (5,36)	440 (11,8)	500 (13,4)	
5 (0,34)			170 (4,56)	300 (8,04)	560 (15,0)	560 (15,0)	670 (18,0)	
7-inches w.c. (17 mbar)	10 (0,69)	200 (5,36)	380 (10,2)	580 (15,5)	830 (22,2)			
	20 (1,4)	280 (7,50)	610 (16,3)	780 (20,9)				
	40 (2,8)	400 (10,7)	780 (20,9)					
	60 (4,1)	570 (15,3)	1300 (34,8)					
	80 (5,5)	650 (17,4)						
	100 (6,9)	750 (20,1)						
125 (8,6)	860 (23,0)							
150 (10,3)	1130 (30,3)							

Shaded areas indicate maximum allowable inlet pressure is exceeded.

1. Deviation from setpoint is -1 to +2,0-inches w.c. (-2,5 to +5 mbar).

**Table 8. Types Y690AH and Y690AHM Capacities**

OUTLET PRESSURE RANGE, CONTROL SPRING PART NUMBER, AND COLOR	OFFSET FROM SETPOINT	OUTLET PRESSURE SETTING	INLET PRESSURE, PSIG (bar)	3/4-INCH BODY SIZE					
				Orifice Size, Inches (mm)					
				Capacities in SCFH (m <sup>3</sup> /h(n)) of Air					
				1/8 (3,2)	1/4 (6,4)	3/8 (9,5)	1/2 (12,7)	9/16 (14,3)	
4 to 8-inches w.c. (10 to 20 mbar)  1B653827052 Red	1-inch w.c. (2 mbar)	7-inches w.c. (17 mbar)	1 (0,069)	70 (1,88)	180 (4,82)	190 (5,09)	320 (8,58)	340 (9,11)	
			5 (0,34)	170 (4,56)	350 (9,38)	380 (10,2)	400 (10,7)	750 (20,1)	
			8 (0,55)	180 (4,82)	410 (11)	420 (11,3)	460 (12,3)		
			20 (1,4)	400 (10,7)	480 (12,9)	500 (13,4)			
			35 (2,4)	510 (13,7)	650 (17,4)	700 (18,8)			
			75 (5,2)	600 (16,1)	740 (19,8)				
7 to 16-inches w.c. (17 to 40 mbar)  1B653927022 Olive drab	1-inch w.c. (2 mbar)	11-inches w.c. (27 mbar)	1 (0,069)	70 (1,88)	120 (3,22)	150 (4,02)	180 (4,82)	190 (5,09)	
			5 (0,34)	120 (3,22)	220 (5,9)	270 (7,24)	410 (11)	580 (15,5)	
			8 (0,55)	130 (3,48)	330 (8,84)	350 (9,38)	420 (11,3)		
			20 (1,4)	270 (7,24)	460 (12,3)	470 (12,6)			
			35 (2,4)	400 (10,7)	480 (12,9)	500 (13,4)			
			75 (5,2)	500 (13,4)	730 (19,6)				
15-inches w.c. to 1.2 psig (37 mbar to 83 mbar)  1B537027052 Yellow	5-1/2-inches w.c. (14 mbar)	15-inches w.c. (37 mbar)	2 (0,14)	70 (1,88)	390 (10,5)	700 (18,8)	850 (22,8)	890 (23,9)	
			6 (0,41)	190 (5,09)	720 (19,3)	1270 (34)	1630 (43,7)		
			10 (0,69)	260 (6,97)	1070 (28,7)	1500 (40,2)			
			30 (2,1)	530 (14,2)	1850 (49,6)	1900 (50,9)			
			60 (4,1)	900 (24,1)	2700 (72,4)				
			150 (10,3)	1990 (53,3)					
			1.2 psig (83 mbar)	2 (0,14)	70 (1,88)	320 (8,58)	470 (12,6)	630 (16,9)	540 (14,5)
				6 (0,41)	190 (5,09)	540 (14,5)	1000 (26,8)	1100 (29,5)	
				10 (0,69)	240 (6,43)	790 (21,2)	1100 (29,5)		
				30 (2,1)	520 (13,9)	1600 (42,9)	1880 (50,4)		
				60 (4,1)	880 (23,6)	2600 (69,7)			
				150 (10,3)	1920 (51,5)				

☐ - Shaded areas indicate inlet pressure is too high for orifice size.

# Bulletin 71.1:Y690A

**Table 8. Types Y690AH and Y690AHM Capacities (continued)**

OUTLET PRESSURE RANGE, CONTROL SPRING PART NUMBER, AND COLOR	OFFSET FROM SETPOINT	OUTLET PRESSURE SETTING	INLET PRESSURE, PSIG (bar)	3/4-INCH BODY SIZE					
				Orifice Size, Inches (mm)					
				Capacities in SCFH (m <sup>3</sup> /h(n)) of Air					
				1/8 (3,2)	1/4 (6,4)	3/8 (9,5)	1/2 (12,7)	9/16 (14,3)	
1.2 to 2.5 psig (83 to 172 mbar) 1B537127022 Light green	0.2 psig (14 mbar)	1.2 psig (83 mbar)	2 (0,14)	90 (5,41)	170 (4,56)	270 (7,24)	380 (10,2)	400 (10,7)	
			6 (0,41)	140 (3,75)	350 (9,38)	570 (15,3)	660 (17,7)	830 (22,2)	
			10 (0,69)	150 (4,02)	460 (12,3)	780 (20,9)	910 (24,4)		
			30 (2,1)	430 (1,15)	1200 (32,2)	1330 (35,6)			
			60 (4,1)	670 (18)	1920 (51,5)	1810 (48,5)			
		2.5 psig (172 mbar)	6 (0,41)	100 (2,68)	200 (5,36)	350 (9,38)	460 (12,3)	530 (14,2)	
			10 (0,69)	130 (3,48)	380 (10,2)	440 (11,8)	670 (18)		
			30 (2,1)	330 (8,84)	760 (20,4)	800 (21,4)			
			60 (4,1)	580 (15,5)	1500 (40,2)	1740 (46,6)			
			150 (10,3)	1150 (30,8)	2600 (69,7)				
2.5 to 4.5 psig (172 to 310 mbar) 1B537227022 Light blue	0.3 psig (21 mbar)	2.5 psig (172 mbar)	4 (0,28)	110 (2,95)	150 (4,02)	240 (6,43)	290 (7,77)	370 (9,92)	
			8 (0,55)	110 (2,95)	280 (7,5)	400 (10,7)	550 (14,7)	620 (16,6)	
			12 (0,83)	150 (4,02)	380 (10,2)	530 (14,2)	720 (19,3)		
			30 (2,1)	330 (8,84)	700 (18,8)	860 (23)			
			60 (4,1)	510 (13,7)	1340 (35,9)	1420 (38,1)			
		4.5 psig (310 mbar)	8 (0,55)	90 (5,41)	190 (5,09)	310 (8,31)	400 (10,7)	420 (11,3)	
			12 (0,83)	120 (3,22)	250 (6,7)	410 (11)	560 (15)		
			30 (2,1)	230 (6,16)	590 (15,8)	640 (17,2)			
			60 (4,1)	460 (12,3)	950 (25,5)	1040 (27,9)			
			150 (10,3)	950 (25,5)	2800 (75)				
4.5 to 7 psig (310 to 483 mbar) 1B537327052 Black	0.7 psig (48 mbar)	4.5 psig (310 mbar)	9 (0,62)	150 (4,02)	330 (8,84)	480 (12,9)	720 (19,3)	770 (20,6)	
			12 (0,83)	160 (4,29)	430 (11,5)	630 (16,9)	890 (23,9)		
			30 (2,1)	400 (10,7)	850 (22,8)	1400 (37,5)			
			60 (4,1)	670 (18)	1590 (42,6)	2100 (56,3)			
			150 (10,3)	1520 (40,7)	3910 (105)				
		7 psig (483 mbar)	9 (0,62)	120 (3,22)	210 (5,63)	400 (10,7)	480 (12,9)	510 (13,7)	
			12 (0,83)	150 (4,02)	290 (7,77)	500 (13,4)	670 (18)		
			30 (2,1)	300 (8,04)	700 (18,8)	1030 (27,6)			
			60 (4,1)	620 (16,6)	1330 (35,6)	1900 (50,9)			
			150 (10,3)	1480 (39,7)	3140 (84,2)				

Shaded areas indicate inlet pressure is too high for orifice size.



**Table 8. Types Y690AH and Y690AHM Capacities (continued)**

OUTLET PRESSURE RANGE, CONTROL SPRING PART NUMBER, AND COLOR	OFFSET FROM SETPOINT	OUTLET PRESSURE SETTING	INLET PRESSURE, PSIG (bar)	1-INCH BODY SIZE					
				Orifice Size, Inches (mm)					
				Capacities in SCFH (m³/h(n)) of Air					
				1/8 (3,2)	1/4 (6,4)	3/8 (9,5)	1/2 (12,7)	9/16 (14,3)	
4 to 8-inches w.c. (10 to 20 mbar) 1B653827052 Red	1-inch w.c. (2 mbar)	7-inches w.c. (17 mbar)	1 (0,069)	70 (1,88)	190 (5,09)	230 (6,16)	320 (8,58)	410 (11)	
			5 (0,34)	170 (4,56)	350 (9,38)	880 (23,6)	1470 (39,4)	1490 (39,9)	
			8 (0,55)	180 (4,82)	410 (11)	1660 (44,5)	1830 (49)		
			20 (1,4)	400 (10,7)	1400 (37,5)	910 (24,4) <sup>(1)</sup>			
			35 (2,4)	550 (14,7)	1780 (47,7) <sup>(1)</sup>	720 (19,3) <sup>(1)</sup>			
			75 (5,2)	800 (21,4)	1080 (28,9) <sup>(1)</sup>				
			150 (10,3)	1300 (34,8) <sup>(1)</sup>					
7 to 16-inches w.c. (17 to 40 mbar) 1B653927022 Olive drab	1-inch w.c. (2 mbar)	11-inches w.c. (27 mbar)	1 (0,069)	70 (1,88)	130 (3,48)	160 (4,29)	180 (4,82)	190 (5,09)	
			5 (0,34)	120 (3,22)	240 (6,43)	400 (10,7)	480 (12,9)	900 (24,1)	
			8 (0,55)	130 (3,48)	330 (8,84)	900 (24,1)	1130 (30,3)		
			20 (1,4)	270 (7,24)	600 (16,1)	1260 (33,8)			
			35 (2,4)	430 (11,5)	1400 (37,5)	920 (24,7) <sup>(1)</sup>			
			75 (5,2)	950 (25,5)	1170 (31,4) <sup>(1)</sup>				
			150 (10,3)	1350 (36,2)					
15-inches w.c. to 1.2 psig (37 mbar to 83 mbar) 1B537027052 Yellow	5-1/2-inches w.c. (14 mbar)	15-inches w.c. (37 mbar)	2 (0,14)	70 (1,88)	390 (10,5)	850 (22,8)	900 (24,1)	1120 (30)	
			6 (0,41)	190 (5,09)	720 (19,3)	1940 (52)	2170 (58,2)		
			10 (0,69)	260 (6,97)	1230 (33)	2520 (67,5)			
			30 (2,1)	530 (14,2)	2190 (58,7)	4230 (113)			
			60 (4,1)	900 (24,1)	3580 (95,9)				
			150 (10,3)	1990 (53,3)					
			1.2 psig (83 mbar)	2 (0,14)	70 (1,88)	360 (9,65)	850 (22,8)	900 (24,1)	1000 (26,8)
				6 (0,41)	190 (5,09)	540 (14,5)	1200 (32,2)	1290 (34,6)	
				10 (0,69)	250 (6,7)	790 (21,2)	2070 (55,5)		
				30 (2,1)	520 (13,9)	1980 (53,1)	3560 (95,4)		
				60 (4,1)	880 (23,6)	3250 (87,1)			
				150 (10,3)	1990 (53,3)				

1. Indicates capacity limited due to boost.

☐ - Shaded areas indicate inlet pressure is too high for orifice size.

## Installation

Y690A Series regulators may be installed in any orientation as long as flow through the body matches the direction of the arrow cast on the body. Normal installation is with the spring case barrel vertical above or below the diaphragm case. However, when using a Type Y690A or Y690AM regulator, for proper operation to achieve the published capacities, the spring case barrel should be

installed pointed down. For actuator casing drainage of the Types Y690AH and Y690AHM, regulators should be installed as shown in figure 3. When exposed to the weather, the spring case vent should be pointed downward to allow condensate to drain. On indoor installations, the vent should be piped outdoors if used in hazardous gas service. External dimensions and connections are shown in figure 4.

# Bulletin 71.1:Y690A

**Table 8. Types Y690AH and Y690AHM Capacities (continued)**

OUTLET PRESSURE RANGE, CONTROL SPRING PART NUMBER, AND COLOR	OFFSET FROM SETPOINT	OUTLET PRESSURE SETTING	INLET PRESSURE, PSIG (bar)	1-INCH BODY SIZE				
				Orifice Size, Inches (mm)				
				Capacities in SCFH (m <sup>3</sup> /h(n)) of Air				
				1/8 (3,2)	1/4 (6,4)	3/8 (9,5)	1/2 (12,7)	9/16 (14,3)
1.2 to 2.5 psig (83 to 172 mbar)  1B537127022 Light green	0.2 psig (14 mbar)	1.2 psig (83 mbar)	2 (0,14)	90 (2,41)	180 (4,82)	360 (9,65)	480 (12,9)	510 (13,7)
			6 (0,41)	140 (3,75)	350 (9,38)	850 (22,8)	680 (18,2)	840 (22,5)
			10 (0,69)	150 (4,02)	500 (13,4)	1090 (29,2)	1360 (36,4)	
			30 (2,1)	490 (13,1)	1240 (33,2)	3130 (83,9)		
			60 (4,1)	780 (20,9)	2790 (74,8)	5960 (160)		
		2.5 psig (172 mbar)	150 (10,3)	1890 (50,7)	3000 (80,4)			
			6 (0,41)	110 (2,95)	210 (5,63)	510 (13,7)	520 (13,9)	530 (14,2)
			10 (0,69)	140 (3,75)	380 (10,2)	600 (16,1)	670 (18)	
			30 (2,1)	440 (11,8)	800 (21,4)	1780 (47,7)		
			60 (4,1)	660 (17,7)	1950 (52,3)	5710 (153)		
2.5 to 4.5 psig (172 to 310 mbar)  1B537227022 Light blue	0.3 psig (21 mbar)	2.5 psig (172 mbar)	4 (0,28)	110 (2,95)	150 (4,02)	320 (8,58)	330 (8,84)	370 (9,92)
			8 (0,55)	140 (3,75)	280 (7,5)	550 (14,7)	570 (15,3)	700 (18,8)
			12 (0,82)	150 (4,02)	380 (10,2)	720 (19,3)	740 (19,8)	
			30 (2,1)	330 (8,84)	700 (18,8)	1420 (38,1)		
			60 (4,1)	510 (13,7)	1350 (36,2)	3160 (84,7)		
		4.5 psig (310 mbar)	150 (10,3)	1560 (41,8)	5160 (138)			
			8 (0,55)	90 (2,41)	190 (5,09)	380 (10,2)	400 (10,7)	420 (11,3)
			12 (0,82)	120 (3,22)	250 (6,7)	470 (12,6)	660 (17,7)	
			30 (2,1)	300 (8,04)	590 (15,8)	1050 (28,1)		
			60 (4,1)	490 (13,1)	950 (25,5)	2400 (64,3)		
4.5 to 7 psig (310 to 483 mbar)  1B537327052 Black	0.7 psig (48 mbar)	4.5 psig (310 mbar)	9 (0,62)	160 (4,29)	330 (8,84)	650 (17,4)	750 (20,1)	810 (21,7)
			12 (0,83)	180 (4,82)	430 (11,5)	780 (20,9)	1000 (26,8)	
			30 (2,1)	400 (10,7)	850 (22,8)	1610 (43,1)		
			60 (4,1)	680 (18,2)	1590 (42,6)	2830 (75,8)		
			150 (10,3)	1600 (42,9)	4650 (125)			
		7 psig (483 mbar)	9 (0,62)	120 (3,22)	210 (5,63)	460 (12,3)	480 (12,9)	510 (13,7)
			12 (0,83)	160 (4,29)	290 (7,77)	600 (16,1)	690 (18,5)	
			30 (2,1)	290 (7,77)	700 (18,8)	1280 (34,3)		
			60 (4,1)	620 (16,6)	1330 (35,6)	2140 (57,4)		
			150 (10,3)	1560 (41,8)	3210 (86)			

- Shaded areas indicate inlet pressure is too high for orifice size.

## NACE Standard MR0175-92 Compliance

Optional materials are available for applications handling sour gases. These constructions comply with the recommendations of National Association of Corrosion

Engineers (NACE) MR0175-92. The manufacturing processes and materials used by Fisher Controls assure that all products specified for sour gas service comply with the chemical and physical requirements of NACE standard MR0175-92.

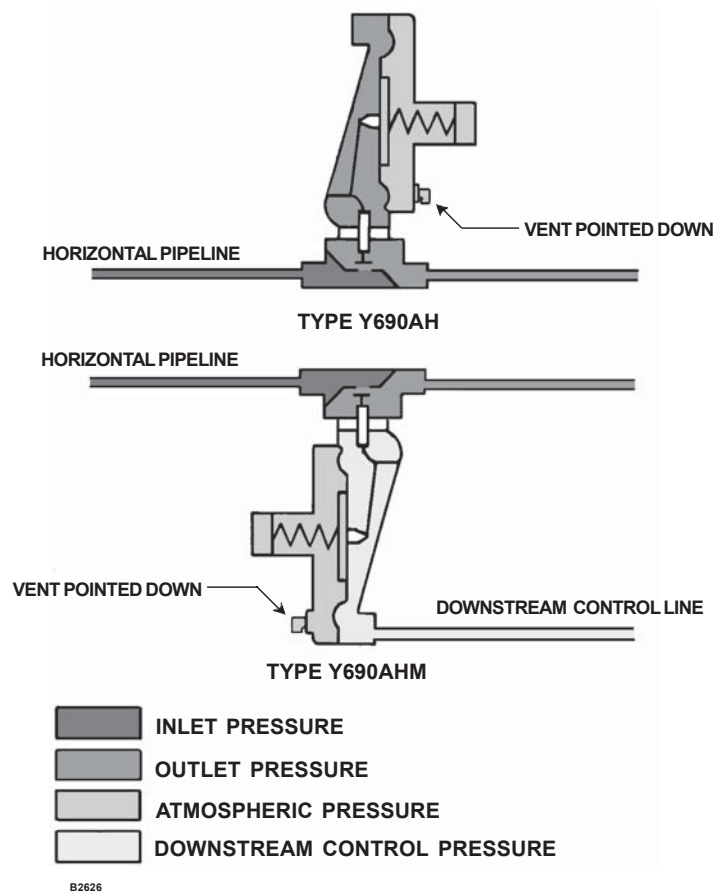

Figure 3. Types Y690AH and Y690AHM Actuator Casing Drainage Schematic

### Ordering Information

When ordering, specify:

#### Application

1. Type of regulator
2. Body, spring case, diaphragm case, and trim materials

3. Control spring range
4. Orifice size

#### Construction

Refer to the page 2 specifications and to each referenced table. Specify the desired selection whenever there is a choice to be made. Always be sure to specify the regulator type number.

# Bulletin 71.1:Y690A

BODY SIZE, INCHES (DN)	A		B		D		F		G	
	Ductile Iron	Stainless Steel or Hastelloy C	Ductile Iron	Stainless Steel or Hastelloy C	Ductile Iron	Stainless Steel or Hastelloy C	Ductile Iron	Stainless Steel or Hastelloy C	Ductile Iron	Stainless Steel or Hastelloy C
3/4, 1 (25)	4.0 (102)	4.12 (105)	2.12 (54)	2.25 (57)	6.19 (157)	6.19 (157)	10.12 (257)	10.12 (257)	1.53 (39)	1.53 (39)

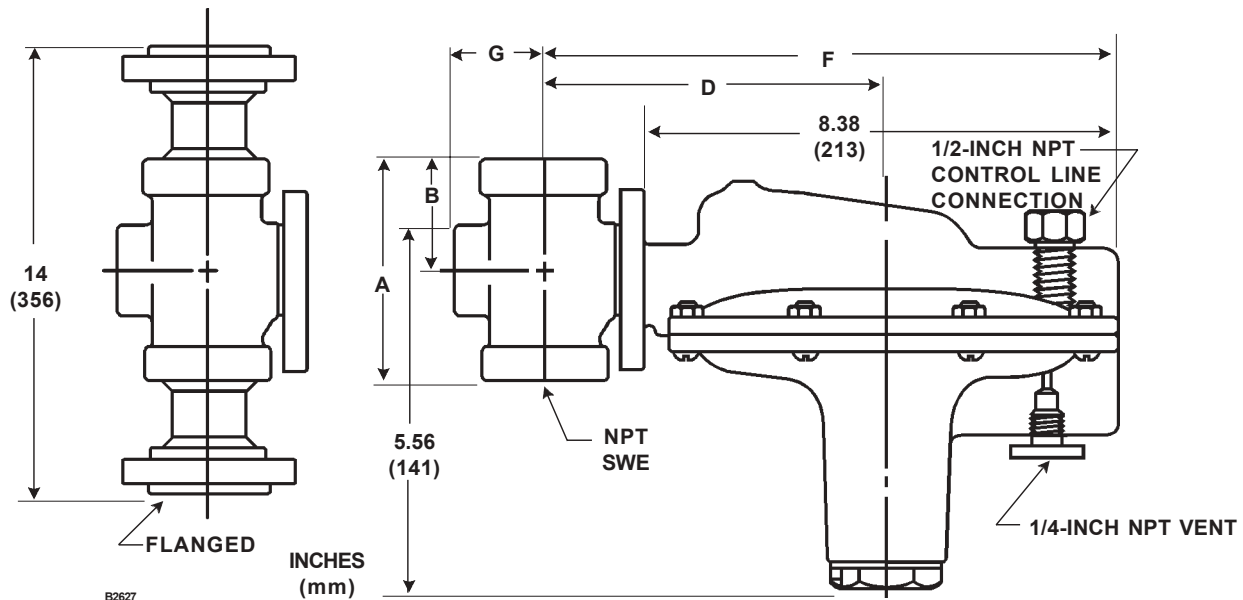

**Figure 4. Dimensions**

Fisher is a mark owned by Fisher Controls International, Inc., a business of Emerson Process Management. The Emerson logo is a trademark and service mark of Emerson Electric Co. All other marks are the property of their respective owners.

The contents of this publication are presented for informational purposes only, and while every effort has been made to ensure their accuracy, they are not to be construed as warranties or guarantees, express or implied, regarding the products or services described herein or their use or applicability. We reserve the right to modify or improve the designs or specifications of such products at any time without notice.

Fisher does not assume responsibility for the selection, use or maintenance of any product. Responsibility for proper selection, use and maintenance of any Fisher product remains solely with the purchaser.

For information, contact Fisher:  
 Marshalltown, Iowa 50158 USA  
 McKinney, Texas 75070 USA  
 28320 Gallardon, France  
 40013 Castel Maggiore (BO), Italy  
 Sao Paulo 05424 Brazil  
 Singapore 128461